

8-2-2015

## Application of Fiscal Incentives for Development of East Natuna Gas Field for Long-Term National Natural Gas Demand

Marwan Batubara

*Department of Chemical Engineering, Faculty of Engineering, Universitas Indonesia, Depok 16424, Indonesia*

Widodo Wahyu Purwanto

*Department of Chemical Engineering, Faculty of Engineering, Universitas Indonesia, Depok 16424, Indonesia, widodo@che.ui.ac.id*

Akhmad Fauzi

*Department of Resources and Environmental Economics, Faculty of Economics and Management, Institut Pertanian Bogor, Bogor 16680, Indonesia*

Follow this and additional works at: <https://scholarhub.ui.ac.id/mjt>



Part of the [Chemical Engineering Commons](#), [Civil Engineering Commons](#), [Computer Engineering Commons](#), [Electrical and Electronics Commons](#), [Metallurgy Commons](#), [Ocean Engineering Commons](#), and the [Structural Engineering Commons](#)

---

### Recommended Citation

Batubara, Marwan; Purwanto, Widodo Wahyu; and Fauzi, Akhmad (2015) "Application of Fiscal Incentives for Development of East Natuna Gas Field for Long-Term National Natural Gas Demand," *Makara Journal of Technology*: Vol. 19: Iss. 2, Article 4.

DOI: 10.7454/mst.v19i2.3036

Available at: <https://scholarhub.ui.ac.id/mjt/vol19/iss2/4>

This Article is brought to you for free and open access by the Universitas Indonesia at UI Scholars Hub. It has been accepted for inclusion in Makara Journal of Technology by an authorized editor of UI Scholars Hub.

## Application of Fiscal Incentives for Development of East Natuna Gas Field for Long-Term National Natural Gas Demand

Marwan Batubara<sup>1</sup>, Widodo Wahyu Purwanto<sup>1\*</sup>, and Akhmad Fauzi<sup>2</sup>

1. Department of Chemical Engineering, Faculty of Engineering, Universitas Indonesia, Depok 16424, Indonesia

2. Department of Resources and Environmental Economics, Faculty of Economics and Management, Institut Pertanian Bogor, Bogor 16680, Indonesia

\*e-mail: widodo@che.ui.ac.id

---

### Abstract

East Natuna gas field, which has proven reserves of 46 trillion cubic feet, is projected to meet long-term natural gas needs. However, CO<sub>2</sub>-content of the gas reserves reaches 71%, leading to expensive development costs. This research investigates the feasibility of the field based on several fiscal incentives. Firstly, gas supply-demand until year 2040 was analyzed. Then, based on the analysis, the field was developed using high CO<sub>2</sub> gas separation technology to produce gas of 1300 MMSCFD in 2023, 2600 MMSCFD in 2031, and 3900 MMSCFD in 2039. Finally, the economic feasibility was assessed using cash flow analysis in accordance with Indonesia's production sharing contract scheme. The results show that the supply-demand gap continues to increase and thus the development is urgently needed. The development cost is estimated around US\$ 27.59 billion. The gas selling prices are assumed at US\$ 8/MMBTU for wellhead, US\$ 11/MMBTU for pipelines, and US\$ 11/MMBTU for LNG. To achieve minimum IRR value of 12%, the government needs to offer incentives of 30-year contract period, profit sharing of 55%: 45%, first tranche petroleum to 10%, and tax holiday of 10 years. Toll fee for Natuna-Cirebon pipeline is US\$ 2.3/MMBTU at IRR of 12.6%.

### Abstrak

**Penerapan Insentif Fiskal dalam Pengembangan Lapangan Gas Natuna Timur Guna Memenuhi Kebutuhan Jangka Panjang Gas Bumi Nasional.** Lapangan gas Natuna Timur yang mempunyai cadangan terbukti 46 TCF diproyeksikan untuk memenuhi kebutuhan jangka panjang gas nasional. Karena cadangan gas mengandung hingga 71% CO<sub>2</sub>, maka dibutuhkan biaya pengembangan yang tinggi. Penelitian ini mempelajari kelayakan ekonomi lapangan melalui penerapan beberapa insentif fiskal. Pertama, pasokan kebutuhan gas hingga tahun 2040 dianalisis. Kemudian, berdasarkan hasil analisis tersebut, lapangan gas dikembangkan dengan teknologi pemisahan CO<sub>2</sub> berkadar tinggi guna memproduksi gas sebesar 1300 MMSCFD di tahun 2023, 2600 MMSCFD di tahun 2031, dan 3900 MMSCFD di tahun 2039. Kelayakan ekonomi proyek kemudian dievaluasi menggunakan analisis aliran uang (*cash flow*) berdasarkan pola kontrak bagi hasil versi Indonesia. Hasil yang diperoleh menunjukkan gap pasokan kebutuhan gas terus meningkat, dan karenanya pengembangan lapangan sangat mendesak dilakukan. Pada harga gas di *wellhead* US\$ 8/MMBTU dan US\$ 11/MMBTU untuk gas pipa/LNG, agar proyek layak dikembangkan dengan IRR minimum 12%, maka pemerintah harus memberikan insentif berupa periode kontrak selama 30 tahun, pola bagi hasil 55% : 45%, *first tranche petroleum* 10%, dan *tax holiday* 10 tahun. Adapun *toll fee* untuk pipa Natuna-Cirebon pada IRR 12,6% adalah US\$ 2,3/MMBTU.

*Keywords:* East Natuna gas field, natural gas, CO<sub>2</sub> separation and storage, gas supply and demand, feasibility analysis

---

### 1. Introduction

The use of natural gas to meet energy demand continues to increase, mainly due to economic growth and the increasing demand for environment-friendly energy. As a country with large gas reserves, Indonesia is able to meet such an increase from a number of gas fields across the archipelago.

One of the fields with huge reserves of gas is the East Natuna Block, Riau Islands. A number of studies have been conducted to develop East Natuna, including a study by Exxon-Mobil, based on exploration license in 1980-2006 [1]. Currently, the government has appointed Pertamina together with Exxon-Mobil, Total SA, and Thailand's PTTEP to develop East Natuna.

Gas consumers consist of households, industries, electricity, transportation, and commercial sectors across Indonesia, with the largest concentration in Java. However, the majority of gas sources are located outside Java, making the lack of infrastructures becomes an obstacle. Therefore, the utilization of East Natuna gas should be supported by the development of gas pipelines from East Natuna to Java Island, namely Natuna-Cirebon gas pipeline.

The average growth of worldwide gas demand reaches 1.6% per year, i.e. from 3.4 trillion cubic meters (TCM) in 2013 to 5 TCM in 2035 [2]. The biggest growth occurs in China (6.6%) and Asia (4.4%). This growth has the potential to be fulfilled by East Natuna gas field, particularly for Japan, Korea and China, as well as Singapore and Thailand, both by pipelines and LNG.

The East Natuna block is situated 1340 km from Jakarta at a depth of 60-150 meters. This field has gas reserves of 222 trillion cubic feet (TCF), consisting of CO<sub>2</sub> (up to 71%), hydrocarbons, especially methane (28%), H<sub>2</sub>S (0.5%) and N<sub>2</sub> (0.4%). The gas reserves can generate approximately 46 TCF [1]. The challenge that the development of the field confronts is to separate and inject CO<sub>2</sub> into the aquifer [3]. This study employed a cryogenic technique of CO<sub>2</sub> separation called *Controlled Freeze Zone* (CFZ) developed by ExxonMobil [4].

This paper aims to examine the projected demand and supply of gas until 2040 and the roles of East Natuna in fulfilling the demand. In addition, field development feasibility analysis using LNG and gas pipeline technologies within the high level and costly CO<sub>2</sub> constraint was performed. This was done through 2 development scenarios with variety of fiscal incentives in accordance with the applicable PSC scheme.

## 2. Methods

This research consists of two main parts. First is to find the projected gas demand until 2040 based on the econometric calculation of gas demand elasticity in accordance with historical data. The projected gas supply was calculated based on the gas balance provided by the Ministry of Energy and Mineral Resources (KESDM) and the Agency for the Assessment and Application of Technology (BPPT) [5,6]. Then, the gas demand and supply were analyzed to find the gap of national gas. Based on the gap, the East Natuna field development scenario was prepared for 2023 to 2052.

Second, the techno-economic feasibility analysis of the project was provided based on LNG and pipeline technologies, using the cash flow method on the PSC

scheme. Because of the high cost of CO<sub>2</sub> treatments, various PSC incentives were analyzed to provide a feasible field development based on to the following: (a) Scenario 1: Feasibility analysis of field development using LNG plant and Natuna-Cirebon gas pipeline in accordance with the upstream contract scheme; (b) Scenario 2: Feasibility analysis of field development using LNG plant based on upstream scheme, and the Natuna-Cirebon pipeline in accordance with the downstream scheme.

**Gas demand.** The magnitude of gas demand depends on the GDP growth and the elasticity of gas demand [7]. Projected national gas demand until 2040 was calculated using the elasticity of gas demand of industrial sectors, households, electricity, and transport to the growth of national GDP.

The equation used to calculate the projected gas demand by sector was:

$$E_{D_n} = E_{D_{n-1}} + (E_{D_{n-1}} \times e \times GDP_{growth}) \quad (1)$$

Where:

$E_{D_n}$  : Demand for gas year n (in energy unit)

$E_{D_{n-1}}$  : Demand for gas year n-1 (in energy unit)

$GDP_{growth}$  : GDP growth (%)

$e$  : Elasticity

Elasticity of each sector was calculated based on the average historical data in 1991-2010 issued by KESDM [8]. The elasticities in 2011-2012 for industrial sectors, households, transport, and electricity were 1.00, 4.00, 0.50, and 1.03 respectively. While the projected elasticities in 2013-2040 for industrial sectors, households, transport, and electricity were 1.00, 0.25, 0.50 and 1.03 respectively.

Meanwhile, the projected GDP growth until 2040 was obtained from the MP3EI [9]. Furthermore, the calculation of gas demand per sector was performed using INOSYD model developed by Faculty of Engineering, University of Indonesia.

Gas demand for exports to countries like China, Japan, Korea, Taiwan, Singapore, and Thailand were also projected to grow, approximately 1.5% per year [2]. Thus, the East Natuna field has the potential to meet this export requirements, with the allocation of approximately 20% of the total production volume.

**Gas supply.** Gas supply was obtained from the Gas Balance issued by KESDM in the forms of LNG, CBM and gas pipelines, based on: a) existing supplies, actively-producing gas fields; b) project supplies, fields

that are being developed; c) and potential supplies, oil and gas fields that are being explored [10].

The national LNG supplies were provided by Arun, Badak, and Tangguh fields, as well as fields that are now being developed, namely Donggi-Senoro and Masela. Approximately 80% of the national gas production was in the form of LNG with a production capacity as shown in Table 1. The projected supplies of gas that can be produced by the entire LNG plants grow approximately 2% per year on average.

CBM supplies have been initiated in 2013 by producing of 0.5 MMSCFD from South Sumatra. In accordance with the plan by the KESDM, the projected production of CBM will reach 500 MMSCFD in 2015, 1,000 MMSCFD in 2020, and 1,500 MMSCFD in 2025 [10].

Gas pipelines were supplied from fields that spread all over Java, Sumatra, Kalimantan, Riau Islands, and South Sulawesi with a growth of 4% per year. Export natural gas pipeline came from Grissik and West Natuna. The entire gas supplies were then compiled and calculated as a source of gas supplies to consumers.

The largest consumers of national gas can be found in the western part of Java, East Java, Central Java, North Sumatra, and South Sumatra. The western part of Java and East Java absorb about 2/3 and 1/4 of the national gas supplies respectively. In the future, though consumption will spread, Java will still consume about 70% of the national gas supplies [11].

To meet national gas demand, it was assumed that the Master Plan for the National Natural Gas Transmission and Distribution Network (the Decree of Ministry of KESDM No.2700K/11/2012 EMR) in the form of gas pipelines, LNG plant and LNG receiving terminals

Table 1. LNG Plants in Indonesia

Field	Reserve (TCF)	Plant	Capacity (MTPA)
Arun	19,7	Train 1,2,3	5.1
		Train 4,5	4.4
		Train 6	2.5
Badak & Mahakam	14 & 26	Train A & B	6.4
		Train C & D	4.6
		Train E & F	5.0
		Train G & H	6.2
Tangguh	17	Train 1	3.8
		Train 2	3.8
		Train 3	3.8
		Train 4	3.8
Donggi-Senoro	3	Train 1	2
Masela	18	Train 1	2.5
		Train 2	2.5

proceeded according to the plan. The completion of these facilities is a prerequisite for the development of the East Natuna field, including the construction of the Natuna-Cirebon pipeline and the LNG plant. East Natuna also needs to be connected to the Trans ASEAN Gas Pipe, TAGP [12].

**Field development strategy.** Strategy for the development of East Natuna gas field is shown in Figure 1. The development works included the constructions of offshore gas fields and the processing of acid gas that includes the separation of a high content of CO<sub>2</sub> using CFZ technology carried out in offshore Central Processing Facilities (CPF). Furthermore, hydrocarbons, especially the separated methane, would be channeled into a piping system and LNG plants in Natuna Island.

**Gas production scenarios.** The East Natuna field was put into scenarios that produced gas in three phases, namely 1300 MMSCFD in 2023, 2600 MMSCFD in 2031, and 3900 MMSCFD in 2039. In the first phase, 800 MMSCFD cleaned gas was allocated to pipeline and 500 MMSCFD to LNG plant. In the second phase, 1600 MMSCFD of cleaned gas was for pipeline and 1000 MMSCFD to LNG plant. In the last stage, 2900 MMSCFD of cleaned gas was assigned for pipeline and 1000 MMSCFD for LNG plant (see Figure 2).

**Estimated development costs.** The estimated cost of the development of East Natuna field was calculated based on the cost components of the following capital and non-capital works: 1). Field acquisition, permitting, signatory bonuses, and land use rights based on the SKK Migas Decrees with a total cost of US\$ 85 millions [13]; 2). Field exploration that consisted of drilling, well logging, geological and geophysical analysis, 3D seismic, processing and analysis of data with a total cost of US\$ 1.368 billions [14]; 3). Development of 26 wells with a production capacity of 1300 MMSCFD and a flow rate of 350 MMSCFD per well, using a 9-5/8 inch pipe, with a total cost of US\$ 2.392 billions [15]. 4). Development of

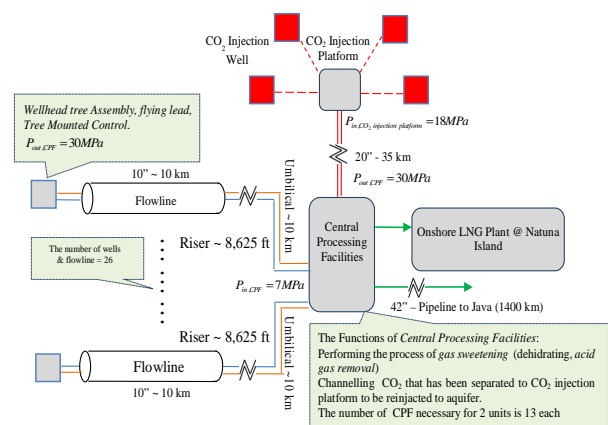
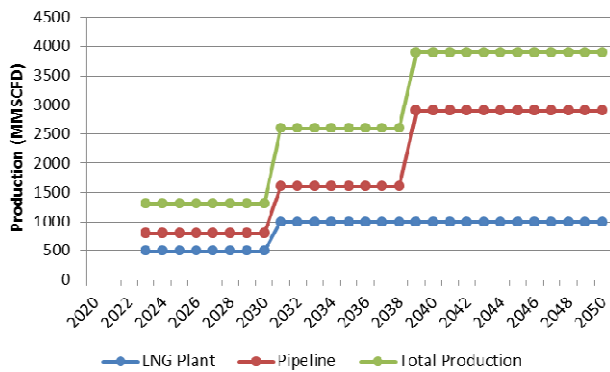

Figure 1. East Natuna Field Development Strategy



**Figure 2. Scenarios for Gas Production of East Natuna Field**

subsea facilities that consists of subsea trees assembly, umbilicals, flowlines, risers, control equipment and pipes, with a total cost of US\$ 2.102 billions [16]. 5). Development of Central Processing Platform (CPF) based on the field cost of Platong II with a capacity of 330 MMSCFD and a total cost of US\$ 3.1 billions [17]. Using the DOE cost scaling method, the estimated cost of 2 Natuna’s CPF is US\$ 7.807 billions; 6). Development of CO<sub>2</sub> separation facilities based on ExxonMobil’s CFZ project in LaBarge, US, and facilities for CO<sub>2</sub> injection into the aquifer, with a total cost of US\$ 11.281 billions [18]; 7). Construction of onshore infrastructure on Natuna Island to support development activities, including marine transportation, communication and accommodation, with a cost of US\$ 500 millions [15]; 8). The development of LNG plant on Natuna Island, along with the 200-km gas pipeline, with a capacity of 3.8 MTPA, according to a study by Songhurst reaches US\$ 2.763 billions [19]; 9). Construction of 2 x 42 inch Natuna-Cirebon gas pipelines, 1400 km length and a capacity of 3200 MMSCFD based on a model developed by Mahmood Moshfegian and David Hairston with a total cost by US\$ 4.455 billions [20]; 10). The owners’ cost which refers to the cost of project management, operations during the construction period, and others by US\$ 1.688 billions [15]. The total estimated development cost of the project based on the two analysis scenarios is shown in Table 2.

**Economic feasibility simulation.** Based on the project investments cost presented in Table 2, a simulation of economic feasibility based PSC scheme was carried out with an IRR target of at least 12% and positive NPV. The targeted minimum gas-selling price is US\$ 8/MMBTU for wellhead and US\$ 11/MMBTU for LNG and gas pipelines. The scheme for the Indonesian PSC calculation currently applicable is shown in Figure 3.

Due to the high development cost resulted from the CO<sub>2</sub> treatments, whilst the project development should be feasible, incentives should be given in the forms of contract period, profit-sharing scheme, first trench

petroleum (FTP), and taxes. Based on the targeted gas selling price as indicated above, the feasibility of the project was initially calculated under ‘basic conditions’ (base case), with an incentive of the contract period of 30 years, which according to the regulation, it should be only 20 years. The summary of assumption used on the PSC regime is shown in Table 3.

Furthermore, since the economic analysis of the project under the base case condition was found not feasible, then in order to obtain a minimum IRR of 12% and a

**Table 2. Total Estimated Development Cost Based on Economic Analysis Scenarios**

Development Cost	Scenario 1	Scenario 2
Capital Cost (US\$)	22,473,622	18,312,087
Non-Capital Cost	4,703,428	4,373,385
<b>Total Investment Cost</b>	<b>27,141,050</b>	<b>22,685,473</b>

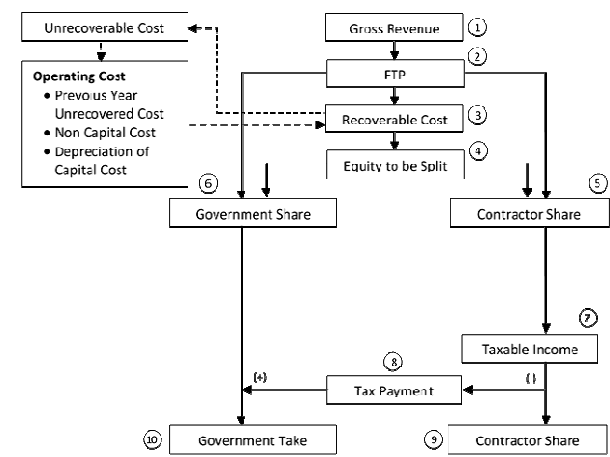

**Figure 3. The Diagram of Indonesia’sPSC[21]**

**Table 3. Summary of Assumption Used in PSC Regime**

Parameter (Unit)	Scenario 1	Scenario 2
Government Share (%)	70	70
Contractor Share (after tax) (%)	30	30
FTP (%)	20	20
Tax (%)	40	40
Contract Period (yr)	30	30
Depreciation Method	Declining Balance	Declining Balance
Discount Rate (%)	10	10
LNG Price (US\$/MMBTU)	11,00	11,00
Inlet Gas Price (US\$/MMBTU)	-	8,00
Outlet Gas Price (US\$/MMBTU)	11,00	-

positive NPV value, other incentives were given in the forms of higher profit-sharing, FTP reduction and tax holiday. In this case, the feasibility was calculated based on the profit sharing of higher than 30%, FTP of smaller than 20% and tax holiday of more than 5 years.

The feasibility of Natuna-Cirebon gas pipeline using downstream contract scheme was analyzed by the calculation of toll fee in accordance with the model set forth in the Regulation of the Regulatory Agency for Downstream Oil and Gas (BPH Migas) No. 8/2013 [22]. The appropriate IRR for the construction of new pipeline, in accordance with the value of WACC (Weighted Average Cost of Capital) plus IRR incentives, should reach 12.45%.

### 3. Result and Discussion

**Projected Gas Demand.** Based on Figure 4, it can be seen that gas demand continues to increase along with the increase in GDP, particularly in the industrial and electricity sectors, i.e. 6 and 4-fold increases within 30 years respectively. Overall, gas demand increases 4-fold from 2010 to 2040. Therefore, the gas production or supply should be increased.

**The Role of East Natuna in Filling Supply-Demand Gap.** Based on the projected gas supply-demand until 2040, a description of gas deficits, which will keep on growing since 2020 (see Figure 5), was obtained. The increase of domestic gas demand will lead to gas deficits from initially about 700 MMSCFD in 2020 to about 5000 MSCFD in 2040.

The total projected gas demand and supply until 2040, which compare the roles of the East Natuna before and after production, is shown in Figure 5. Based on the figure, it can be seen that the gap in the projected gas supply-demand decreases by approximately 20% due to the supply of the East Natuna field. Therefore, it is very relevant to develop the field immediately.

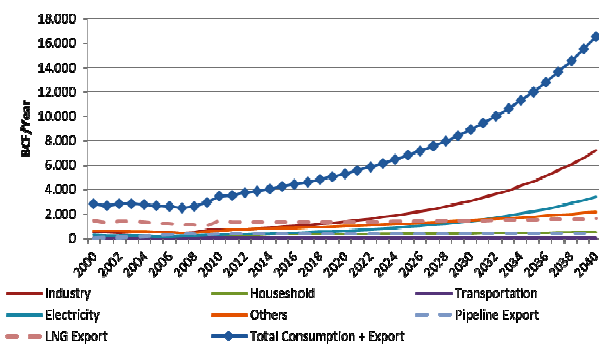

Figure 4. Long-term Domestic Gas Demand

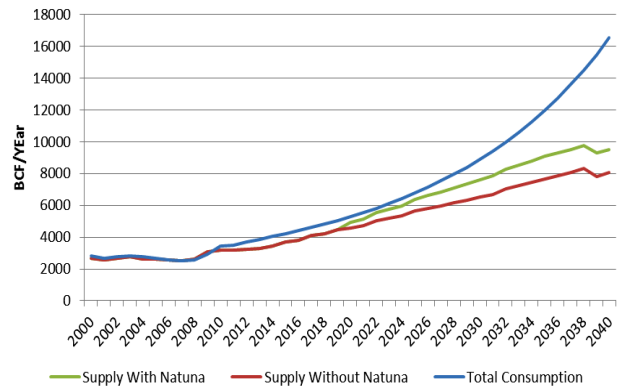

Figure 5. The Role of Natuna in Filling Supply-Demand Gap

**Feasibility of Field Development. Scenario 1.** The calculation of the economic feasibility for Scenario 1 under base case conditions resulted in NPV value of US\$ -2.49 billion and IRR of 8.97%. These imply that the East Natuna field is not worth developing. To be feasible with  $IRR \geq 12\%$ , then incentives of a profit sharing ranging from 30% to 55%, a change of FTP to 10%, and 10-year tax holiday was offered. Table 4 presents changes in the economic feasibility parameters due to changes in the fiscal-incentive variables.

The simulation result showed that for Scenario 1 (see Table 4), on the gas-selling price of US\$ 11/MMBTU for LNG and US\$ 11/MMBTU for gas pipeline, the East Natuna field is worth developing if contractors are given incentives of profit sharing of 45%, FTP of 10% and 10-year tax holiday.

Figure 6 shows the structure of fiscal policy and its impact on the project IRR based on Scenario 1. It can be seen that the profit-sharing incentive variable dominantly influences changes in project feasibility, followed by the variables of tax and FTP.

The provision of the tax holiday incentive in Scenario 1 makes the government’s revenue low enough for the first 10 years, ranging between US\$ 80 million to US\$ 121 million, and it increases significantly on the eleventh year to US\$ 3 billion. The total gross revenue of the project reaches US\$ 321.41 billion, with the government’s revenue of US\$ 110.90 billions and contractors’ revenue of US\$ 99.86 billions.

**Scenario 2.** Simulation results for the economic feasibility of Scenario 2 under the base case conditions generated the NPV value of US\$ -3.54 billion and an IRR of 7.81%. These also imply that the project is not worth developing without offering any incentives. To be feasible, fiscal incentives as simulated in Table 5 should be offered.

**Table 4. Impact of Fiscal Incentives on NPV and IRR in Scenario 1**

LNG Price		US\$ 11/MMBTU					
Outlet Pipeline Price		US\$ 11/MMBTU					
Fiscal Scenario		Profit Sharing Change		FTP @ 10%		Tax Holiday 10 Years	
Profit Sharing (After Tax)		NPV @10%	IRR (%)	NPV @10%	IRR (%)	NPV @10%	IRR (%)
Government	Contractor	(US\$ '000)		(US\$ '000)		(US\$ '000)	
70%	30%	-2,049,951	8.97	-1,664,828	9.14	-581,001	9.69
65%	35%	-399,131	9.81	-41,517	9.98	1,222,949	10.61
60%	40%	1,251,689	10.57	1,581,794	10.74	3,026,898	11.45
55%	45%	2,902,502	11.28	3,205,106	11.44	5,429,868	12.49
50%	50%	4,553,329	11.93	4,828,417	12.09	6,634,796	12.94
45%	55%	6,204,149	12.55	6,451,728	12.69	8,438,745	13.62

**Table 5. Impact of Fiscal Incentives on NPV and IRR in Scenario 2**

LNG Price		US\$ 11/MMBTU					
Inlet Pipeline Price		US\$ 8/MMBTU					
Fiscal Scenario		Profit Sharing Change		FTP @ 10%		Tax Holiday 10 Years	
Profit Sharing (After Tax)		NPV @10%	IRR (%)	NPV @10%	IRR (%)	NPV @10%	IRR (%)
Government	Contractor	(US\$ '000)		(US\$ '000)		(US\$ '000)	
70%	30%	-3,545,499	7.81	-3,220,135	7.96	-1,957,216	8.74
65%	35%	-2,178,527	8.72	-1,876,403	8.87	-402,998	9.75
60%	40%	-811,555	9.54	-532,671	9.69	1,151,221	10.68
55%	45%	555,418	10.30	811,061	10.45	2,705,439	11.53
50%	50%	1,922,390	11.00	2,154,792	11.14	4,259,657	12.32
45%	55%	3,289,362	11.65	3,498,524	11.79	5,813,876	13.06

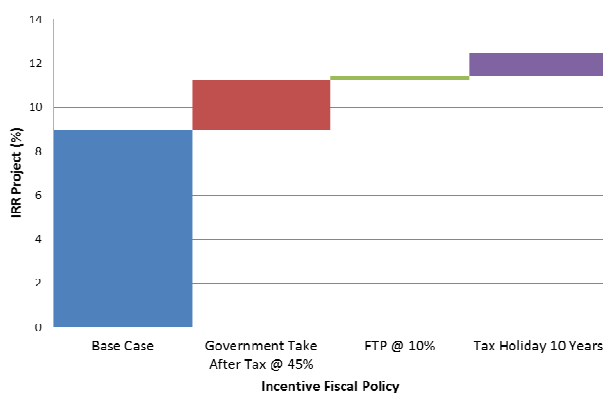
**Figure 6. Changes in IRR Towards Fiscal Incentive Policy for Scenario 1**

Based on the simulation, it was suggested that at the selling price of US\$ 11/MMBTU for LNG and US\$ 8/MMBTU for pipeline gas, the East Natuna field is worth developing if contractors are given profit-sharing incentives after tax of 50%, FTP reduced to 10% and 10-year tax holiday.

Figure 7 presents the changes in IRR due to changes in fiscal incentives for Scenario 2. The profit-sharing variable more dominantly influences changes in the project feasibility than taxes and FTP, so as to serve as a determining factor.

The provision of the tax holiday in Scenario 2 also makes the government's revenue low enough for the first 10 years, ranges between US\$ 60 million to US\$ 100 million, and increases significantly in the eleventh year to US\$ 2.5 billion.

The total gross revenue of the project reaches US\$ 259.93 billion, with the government's revenue of US\$ 81.23 billion and contractors' revenue of US\$ 81.05 billion. Thus, it can be concluded that the development of Scenario 1 provides higher state revenue than Scenario 2 by US\$ (110.90-81.23) billion = US\$ 29.67 billion.

**Sensitivity Analysis.** Sensitivity analysis for Scenario 1 was performed to evaluate the impact of changes in capital costs and gas selling prices on the feasibility of the project. Figure 8 shows that if the capital costs

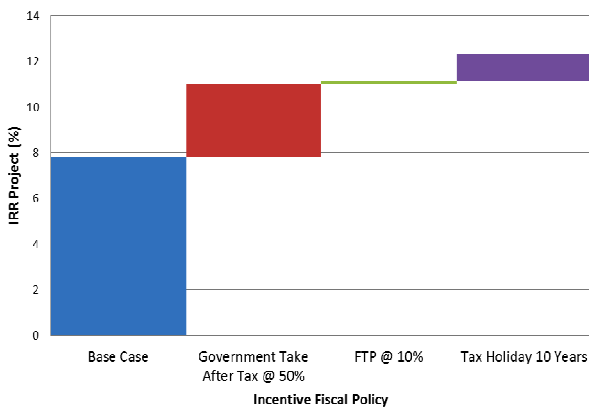

Figure 7. Changes in IRR Towards the Fiscal Incentive in Scenario 2

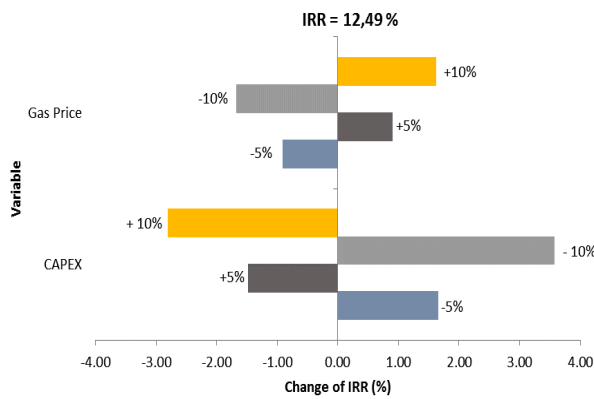

Figure 8. Changes of IRR Due to Changes Capital Costs and in Gas Selling Price

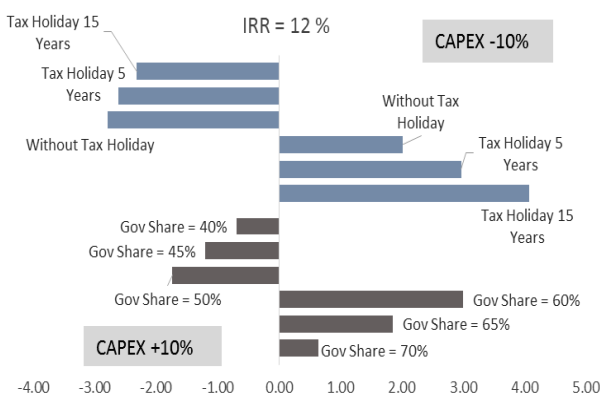

Figure 9. Changes in IRR and Fiscal Incentives Due to Changes in Capital Costs

increase by 10%, then the IRR decreases by 2.81%. The figure also indicates that if the gas-selling price decreases by 10%, then IRR also decreases by 1.68%. Those changes make the project not worth pursuing.

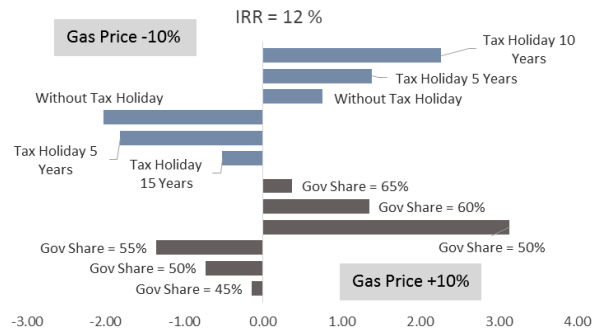

Figure 10. Changes in IRR Due to Changes in Gas Selling Price Under  $\pm 10\%$  Changes of Capital Costs

To bring the project back to a feasible condition then incentives should be increased to the benefit of the contractor. As shown in Figure 9, if the project costs increase by 10%, then to be feasible, the profit split should be changed to 41%:59% and tax holiday should increase to 15 years. In case the capital costs only increase by 5%, then the project will be feasible (IRR=12.13%) if profit split becomes 50%:50% and tax holiday is 12 years.

Instead of allowing more fiscal incentives for the benefit of the contractor, the project could also proceed if the gas-selling price is increased. Figure 10 shows the sensitivity of the project feasibility due to changes of gas selling price, in case the capital costs increase by 10%.

It was found that if the project costs increase by 10%, there is no need to change fiscal incentives (from 45% profit split, 10% FTP and 10-year tax holiday as stipulated in subheading 3.2) if the gas-selling price is increased from US\$ 11/MMBTU to US\$ 12.65/MMBTU. We can deduce that the government could keep fiscal incentives, and hence the state revenues, if the gas selling price increases around 10%.

**Toll-fee natuna-cirebon gas pipelines.** The calculation of the toll-fee rate of the Natuna-Cirebon gas pipelines was performed using the discounted free cash flow with targeted IRR by 12.45%. The calculation shows that at a discount rate of 10%, the NPV value is positive at US\$ 1.29 million and IRR of 12.65%. Therefore, the toll-fee rate of the Natuna-Cirebon gas pipeline according to the targeted IRR is no less than US\$ 2.3/ MMBTU.

#### 4. Conclusions

The increased gap of the projected national gas supply-demand until 2040 indicates that it is urgent to develop East Natuna. The produced gas can be channeled through pipelines and LNG tankers, and it has been simulated in accordance with the calculation of the



project feasibility based on the upstream contract scheme for the gas pipelines (Scenario 1) and the downstream scheme without gas pipelines (Scenario 2).

The simulation results show that the gas field is worth developing if the government provides fiscal incentives in the forms of a contract extension to 30 years, changes in the profit-split from 55% to 45%, and FTP to 10% as well as 10-year tax holiday. It is recommended to select the upstream contract scheme for gas pipelines (Scenario 1) because of the greater revenue that the state will earn, i.e. about US\$ 31.38 billion.

State revenue can increase through offering lower incentives of the profit sharing and taxes as well as increased FTP, by raising the gas-selling price higher than US\$ 11/MMBTU. Further, in case the project costs increase by 10%, for the field development to remain feasible, the government could increase the gas selling price by around 10% without offering more incentives to the contractor.

## References

- [1] Direktorat Jenderal Migas, Blok Natuna D-Alpha dan Blue Print Migas Nasional, 2007. [In Indonesia]
- [2] International Energy Agency (IEA), World Energy Outlook, 2013.
- [3] A. Bachtiar, Blok Natuna D-Alpha: Aspek Geologi Migas, Seminar Natuna, Jakarta.
- [4] P.S. Northrop. The CFZ Process: A Cryogenic Method, *Energy Procedia*, 1 (2009) 171-177.
- [5] Kementerian ESDM, Neraca Gas Nasional 2012-2025, 2012a.
- [6] BPPT. (internet) [cited 2013] Available from: <http://repit.files.wordpress.com/2012/11/bppt-outlook-energi-indonesia>.
- [7] S.C. Bhattacharya, G.R. Timilsina, Energy Demand Models for Policy Formulation, The World Bank, 2009.
- [8] Kementerian ESDM, Kajian Indonesia Energy Outlook, 2012b. [In Indonesia]
- [9] Kemenko Perekonomian Master Plan Percepatan dan Perluasan Pembangunan Ekonomi Indonesia 2011-2025, 2011. [In Indonesia]
- [10] Kementerian ESDM, Rencana Induk Jaringan Transmisi dan Distribusi Gas Bumi Nasional 2012-2025, 2012 c. [In Indonesia]
- [11] H. Nugroho. Energi dalam Perencanaan dan Pembangunan. Bogor: IPB Press, 2009. [In Indonesia]
- [12] Asean Council on Petroleum (ASCOPE), Workshop on Development of NG Resources with CCS, 17-20 March, Bali, 2009.
- [13] Migas Review, (internet) [cited 2013] Available from: <http://migasreview.com/mungkingkah-perizinan-gratis-untuk-kkks-migas.html>.
- [14] W. Partowidagdo. Migas dan Energi Indonesia, Bandung: Development Studies Found, 2009. [In Indonesia]
- [15] B. Guo, A. Ghalambor. Petroleum Production Engineering, A Computer-Assisted Approach. Houston, Tx.: Oxford Publishing, 2007
- [16] B. Yong, B. Qiang *Subsea Engineering Handbook*. Oxford, UK: Gulf Publishing, 2010.
- [17] Hydrocarbons-technology, *Platong II Project, Thailand*, (internet) [cited 2014] Available from: <http://www.hydrocarbons-technology.com/projects/platonggasproject>.
- [18] M.E. Parker, P.S. Northrop, M.T. Duncan. CO<sub>2</sub> Management at ExxonMobil's LaBarge Field, *Energy Procedia*, 4 (2011) 5455-5470
- [19] B. Songhusrt. LNG Plant Cost Escalation, The Oxford Institute Studies, 2014.
- [20] M. Moshfegian, D. Hairston. Offshore Natural Gas Pipeline Transportation Alternatives: Capital Cost Comparison. John Campbell, 2013.
- [21] Lubiantara, Benny, Ekonomi Migas–Tinjauan Aspek Komersial Kontrak Migas, Grasindo, Jakarta, 2012. [In Indonesia]
- [22] BPH Migas, Peraturan BPH No. 8/2013 tentang Tarif Pengangkutan Gas Pipa, 2013. [In Indonesia]