

10-30-2009

## The Influence of Promotion in Constructing Country's Perception, Autobiographical Memory, Emotional Bonding, and Visiting Intention

Jony Oktavian Haryanto

Faculty of Economics, Satya Wacana Christian University, Salatiga, Central Java, Indonesia,  
jonyharyanto@yahoo.com

Follow this and additional works at: <https://scholarhub.ui.ac.id/seam>

---

### Recommended Citation

Haryanto, Jony Oktavian (2009) "The Influence of Promotion in Constructing Country's Perception, Autobiographical Memory, Emotional Bonding, and Visiting Intention," *The South East Asian Journal of Management*: Vol. 3: No. 2, Article 2.

DOI: 10.21002/seam.v3i2.5619

Available at: <https://scholarhub.ui.ac.id/seam/vol3/iss2/2>

This Article is brought to you for free and open access by the Faculty of Economics & Business at UI Scholars Hub. It has been accepted for inclusion in The South East Asian Journal of Management by an authorized editor of UI Scholars Hub.

## **The Influence of Promotion in Constructing Country's Perception, Autobiographical Memory, Emotional Bonding, and Visiting Intention**

Jony Oktavian Haryanto\*

*This paper aims to propose the influence of promotion toward the establishment of country's perception, autobiographical memory (AM), emotional bonding (EB), and visiting intention. The writer would like to propose the direct influence of promotion toward intention to visit. This paper is aimed to see prospects' perception toward its promotion. Next, the writer would like to explore the influence of country's perception, AM and EB toward the intention to visit. It is interesting to understand that they function as crucial factors which are considered deeply by prospects before they decide where to go. Hence, it is important to analyze their influence toward intention to visit and including which one is more dominant.*

*This paper proposes 7 hypotheses to analyze the relationship above. Data is analyzed using Structural Equation Modelling (SEM) with Lisrel 8.80. The data shows that promotion influences country's perception, AM and EB significantly. On the other hand, emotional bonding influences intention to visit significantly. This research has implications that promotions which are held by countries for tourism should be targeted correctly. Media of promotion or time of promotion have to be analyzed promptly in order to gain effective campaign for prospects. On the other hand, the promotion which is able to create EB or AM has to be developed continuously by tourism industry. Furthermore, marketers need to think appropriate marketing strategies to create a strong emotional bonding between prospects and country.*

**Keywords:** *promotion, country's perception, emotional bonding, autobiographical memory, intention to visit.*

---

### **Introduction**

The global financial crisis in the United States and Europe has influenced Asian's tourism industry, where most of the tourists come from United States and Europe. To

overcome the problem, a comprehensive promotion strategy is needed. The promotion strategy should be able to create Autobiographical Memory (AM), a memory stored for a long-term as a result of an experience (Rubin, 2006). Research done

---

\*Jony oktavian haryanto (jonyharyanto@yahoo.com) is an associate professor in marketing at Faculty of Economics Satya Wacana Christian University (52-60 Diponegoro at Salatiga-Central Java Indonesia 50742).

by Haryanto (2008) has proven that there are specific promotions stored in consumer's mind resulted in an intention to purchase.

To overcome the impact of tourist declination, caused by the global financial crisis or travel warning to some countries, a comprehensive promotion strategy is needed. If the promotion done is able to be stored in autobiographical memory, then it will create higher intention to visit the specific country. For example, a promotion which is able to describe and display the beauty of a country pleasingly will be stored in prospects autobiographical memory. If that prospect has a chance to go on vacation, then they will recall their memory and will travel to the location where they have experienced a positive autobiographical memory. This is a long-term benefit for a country because the successful promotion strategy. Moreover, the kind of promotion which is able to increase the emotional bonding should be observed. This is important because if the promotion succeed to create emotional bonding, it is easy to stimulate the bound to be a visiting intention.

What kind of promotion is able to increase a positive autobiographical memory to the prospects is an interesting question to be observed more. Besides that, it is also interesting to know the influence of promotion towards perception of the country and how the promotion done for tourism sector can create an emotional bonding between prospects and the promoted location, so that the influence of the promotion towards the visiting intention can be viewed directly or indirectly.

The thesis that perception of the country might influence the purchasing intention has been observed by previous researchers (Solomon, 2007; Bearden and Teel, 1983; Oliver, 1996). However, the hypothesis that the perception of a country will influence the visiting intention in tourism sector needs to be observed more. It is a fact that nowadays, the perception of a country

holds an important role in tourism industry. For example, Thailand, which is known for the exotic beaches and deep-rooted Asian atmospheres, and Singapore, which is known as Asian's shopping paradise. Seeing a strong perception influence, this research is aimed to search the influence of a country's perception towards AM, and the association with the visiting intention.

## Literature Review

### Promotion

Promotion is an action done by the advertiser aimed to give information or persuade costumers to purchase (Kotler and Keller, 2006; Evanschitzky, Iyer, Plassmann, Niessing, and Meffert, 2006). Seen from the purpose, there are 3 purposes of promotion: to remind, inform, and persuade the prospects. Similarly to the tourism industry, the promotion done is aimed to give information about the beauty and plus point of a country. Promotion is also aimed to persuade prospects to visit a specific area.

Promotion for tourism industry often consists of event marketing, and advertising. Advertisers often use event marketing in tourism world to attract prospects. Some examples are: cultural events, shopping day, discounts, or international sport competition. This event marketing is often used as one of the effective ways to attract prospects' interest to visit.

Furthermore, advertisers greatly advertise the beauty of the country or their special events, in strategic locations, such as airports or high-class magazines. The repetition of advertisements is expected to make the prospects record the label or brand in their autobiographical memory. When prospects obtain the intention to travel, they will recall their positive AM and then decide to travel to the country with positive AM.

### **Perception of the Country**

Solomon (2007) defines perception as a process of choosing, organizing, and interpreting the stimulus accepted by receptor. The process of perception itself can be describe as : stimulus in form of smell, sound, texture, shape, etc. It can be recognized by receptor in form of sight, hearing, smell, feel, taste, and are exposed in consumers' recognition. Consumer's attention towards this exposure will be interpreted. Some of the exposures were not analyzed due to the amount of stimulus and limitation of consumers' cognitive ability. Therefore, not all information received by consumers (tourist prospects) can be recorded well. As a result, a bias appears that prospects only record some information and generalize the perception of the country based on the small amount of the information. This bias influences prospects' perception towards the condition of the visited country. For example, the terrorism issue in Indonesia and the political demonstration in Thailand resulted in travel warning claimed by some countries. In fact, the demonstration in Thailand did not distract the tourism activity. The advertiser (country) needs to have an effective promotion strategy to establish a strong insight. Security, comfort, and politeness factors need to be communicated through the promotion strategy so the positive perception can be created in prospects' mind.

### **Autobiographical Memory**

Autobiographical memory is defined as a memory from previous experience that will be stored as a long term memory (Braun, Ellis, and Loftus, 2002). Previous experience is a keyword that differentiate autobiographical memory with long term memory. Rubin (2006) explained that autobiographical memory exists when a

specific event is recalled with specific image, e.g. when a tourist has a specific experience when he was visiting a country, then he would make a recall on his experience in associations with cheerfulness, cleanness, etc.

Consumer's memory about branding or branding's experience when he/she visits a country will have a huge consequences into the next decision due to the emotional attachment which was established before. In this matter, autobiographical memory is perceived as a trustable record with strong visualization that would create an original experience. This explain why tourists will tend to visit same countries several times due to this condition. Sutjan, Bettman and Baumgartner (1993) showed that a positive autobiographical memory will lead to a positive attitude toward advertising and enhance the brand evaluation. When an autobiographical memory has been developed, then it will influence prospects' next choices or preferences (Bertsen and Rubin, 2002).

In relation to the country visiting, the positive or negative experience will be memorized strongly in the autobiographical memory. Positive experience when visiting a country will stimulate prospects to conduct other visits, vice versa. Tourists with experience in visiting countries and still eager to visit again due to their satisfaction will memorize those things in their autobiographical memories. This experience will be memorized continuously and will drive to the intention to visit again. When a tourist wants a specific visit continuously then it will be memorized and become an autobiographical memory. This memory become a nostalgia which is continuously constant in the long run.

### **Emotional Bonding**

Macinnis and Park (2005) defined emotional bonding as a "relationship-based

construct that reflects the emotional bond connecting an individual with a consumption entity”, and found that it is comprised of three components: affection (warm feelings for the brand), passion (intense positive feelings for the brand), and connection (“feeling of being joined with the brand”). Moreover, Sadock and Sadock (2007) explained that emotional bonding is caused by motivation and is the highest stage of an emotional and psychological relationship among individuals with specific objects, such as friends, favorite pets, or products.

According to Eberl (2004), this emotional bonding happens because there is trust from both exchanging sides. For example side A and B. the emotional bonding will occur when A feels the benefit in having a relationship with B, and no possibility that B will go against A. Identification that one of the sides is reliable is a must have condition before an emotional bonding occurs. Popper and Ward (1987) stated that a new relationship will generate emotional bonding if the relationship continues over and over again. Furthermore, Bansal and Taylor (2005) proposed that emotional bonding is one variable considered as mooring factor, i.e. variable that create barrier for costumers to switch to other service providers.

Eberl shows that emotional bonding occurs because of there is an observation of one side to the other side. Related with the tourism industry, before emotional bonding occurs, prospects will observe the country which will be visited. The observation consists of the nature’s beauty, characters of the country, perception of the character, etc. These observations make prospects conclude to have emotional bonding with the country.

Related to above explanation, which states that repetitive usage will create an emotional bonding in the user, Lindstorm (2007) stated that it needs a strong attitude foundation before someone becomes

loyal to a country. We can see this from some tourists who settle down in a certain country for years, or even decide to move to the country as a result of strong emotional bonding. This relationship can be illustrated as a pyramid, where someone who is on the highest point of the pyramid has a strong attitude relationship with the brand, and there’s a possibility to purchase it and being loyal to in a long time. At the lowest stage is presence, which means prospects are acquainted with something promising about the country and its more than awareness, so they can accept it or decline it. To offer accepted choices, a country should avoid negative things. People should think that the country will fulfill their basic needs, such as security, comfort, transportation, and other infrastructures, will be adequate with the values possessed. If the country fails to fulfill any of these individual criteria, the country will stay in the presence-stage and cannot advance to the relevant stage.

To advance to the next step, a country need to experience consumption, this is the visit itself. People will move to this step when they have confirmed themselves that the country is giving the basic promises. Next, a country should be able to find a dimension which will give some advantages than the competitors, rationally and emotionally. Building advantages by managing emotional necessities will create a stronger emotional bonding (Leivin and Paige 2003; Lutjhe, 2004). The highest stage is the bondage, where prospects reach the degree of country bondage, so they excluded other countries from their mind.

### **Intention to Visit**

Intention is defined as the subjective possibility of a person to conduct certain action (Gunter and Furnham, 1998). This will be developed when a person creates a plan about his/her future behavior. Rook (1987) stated that intention is a basic unit

in the network plan when a person conducts a cognitive action which is future oriented. Intention is based on the future action. Furthermore, they explained that there are three constructs regarding to intention, they are: (1) Intention as a hope (2) intention as a plan (3) intention as a want. These three constructs are usually used to measure intention.

Construct intention as an expectation is the most commonly used and popular (Rook, 1987). This refers to the individual assessment regarding to subjective possibilities that will create future behavior. Basically, measurement of intention to consume involved attitude and subjective norm based on behavioral intention theory (Rook and Fisher, 1995). Behavioral intention usually is predicted based on multiattribute model (Rook and Fisher, 1995). Darley and Lim (1986) conducted a research using Technology Acceptance Model (TAM) as multiattribut model to predict intention to consume on technology based on its utility. Rook and Fisher (1995) defined attitude to consume as a positive or negative feeling to the next target behavior. Hence, Rook and Fisher stated that intention to consume depends on the strength of conducting a specific action. In this article, I do not differentiate between intention to visit and intention to revisit. The reason is that there is no significant difference between those two in term of tourism industry (Bansal and Taylor, 2005).

## Methodology

### Research Questions

To overcome the suppression of tourism industry, a comprehensive promotion strategy which is able to increase prospects' visiting intention is needed. It is important to know the direct or indirect influence of promotion towards the visiting intention.

The questions raised in this research are:

1. How is the influence of promotion towards perception of a country?
2. How is the influence of promotion towards autobiographical memory?
3. How is the influence of promotion towards emotional bonding?
4. How is the influence of promotion towards visiting intention?
5. How is the influence of country's perception towards visiting intention?
6. How is the influence of autobiographical memory towards visiting intention?
7. How is the influence of emotional bonding towards visiting intention?

### Conceptual Model

Several things that influence prospects' intention to visit a country has been stated before. Therefore, this research is aimed to see some determiners of visiting intention. Consequently, this research emphasizes more in promotion factor in building perception of the country, emotional bonding, autobiographical memory and at the end, all will lead to the creation of visiting intention. Figure 1 explains the conceptual mode which will be established in this research.

### Hypotheses

From the literature review, it could be analyzed that promotion has a significant influence towards intention construction to visit a country as a tourism object. For tourism industry, promotion which is done properly will not just increase the visit of the tourists each year, but also to elevate the country's perception so it will greatly impact other sectors.

This research is basically aimed to see the factors which influence intention to visit a country. It is important to identify what significant factors needed to stimulate

Figure 1. Conceptual Model

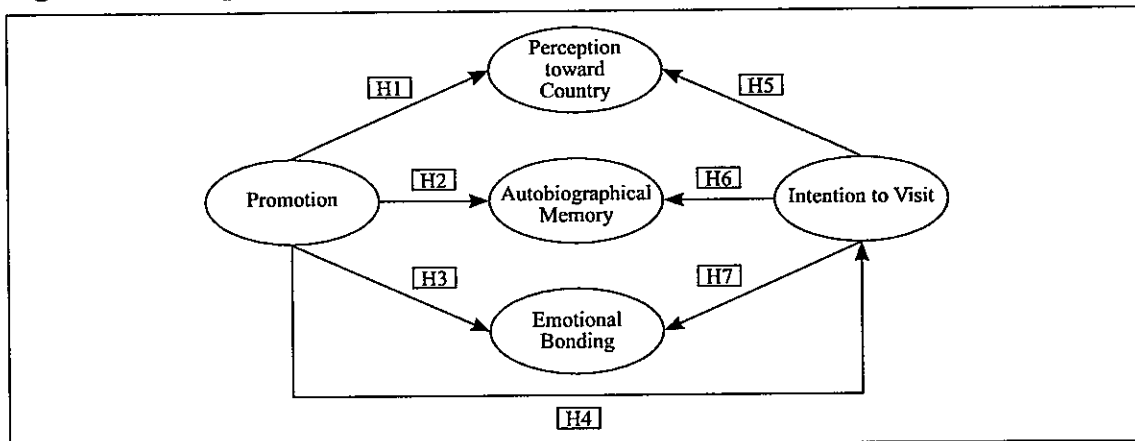

prospects to visit a certain country. It is easier for the advertisers to concept the promotion strategy to communicate the uniqueness of their country, if they identify the factors.

### The Relationship between Promotion and Perception

In the previous research, it has been proven that promotion has a significant influence towards a brand's or a product's perception (Kotler and Keller, 2006; Haryanto, Raharjo, Timotius, Kusumo, Purwanti, 2005; Haryanto, 2008). Similar thesis should be suitable to revive a positive perception of a country. Nevertheless, researches that observe directly the influence of promotion to create a country's perception are rarely to be found, compared to those which observe the influence of promotion towards the form of product's of label's perception. It is proven that an adequate and consecutive promotion will increase prospects' perception towards the product (Solomon, 2007). Even a consistent promotion is able to change prospects' perception towards a country. As an example, a vast promotion by China has change the perception of dirty, corrupt, and restricted country to one of the most popular country for tourism in Asia (Bhram, 2001).

An untargeted promotion not only spend lots amount of money, but also able to

create negative perceptions of the country. For example, promotion done by Indonesia in VISIT INDONESIAN YEAR 2008, which targeted seven million tourists, was not supported by sufficient infrastructure (Flood in the airport at the beginning of year and rotating electricity shut down in almost all parts of Indonesia as a result of energy crisis). This was not a goal for tourism in Indonesia and it would create negative word of mouth for tourists who visited Indonesia. Based on the explanations above, a hypoteses is proposed as follows: H1: The better the promotion is, the better perception will be made for the country.

### The Relationship between Promotion and Autobiographical Memory

Promotion done effectively and intensively will be recorded in prospects' memory. This will be a longterm memory and finally becomes an autobiographical memory. Even though prospect does not travel as soon as he/she sees the advertisement, but he/she will recall the positive autobiographical memory about a country when he/she wants to travel. (Sutjan et al.1993).

The thesis about promotion influences autobiographical memory has been proven by Haryanto (2008) in context of child's option towards a product. A research is needed to understand the role of promotion

for the forming of autobiographical memory in adults in context of tourism. If the prospect has a positive autobiographical memory of a country, and it's stimulated intensively by promotion, it will be easy to attract the prospect to visit a country. This also means that promotion is not a stimulus to travel, but also a potential future market that should be seriously managed by advertisers.

In more formal language, a hypotheses is proposed as follows:

H2: The better the promotion is, the stronger the autobiographical memory formed in prospect towards the visited country.

### **The Relationship between Promotion and Emotional Bonding**

The thesis about promotion influences significantly towards emotional bonding has been proven by Macinnis and Park (2005) for product context. In tourism context, It is needed to search deeper about the correlation of promotion in creating prospect's emotional bonding towards the promoted country. If the promotion done presents an impressive memory, and is recorded in prospect's autobiographical memory that makes a desire in them, then a strong emotional bonding is created in prospect, although he/she has never been there. For example, an intensive promotion about the beauty of Venice, added with the romantic gondola trip through the rivers of Venice, makes so many youngsters dream about having their honeymoon in Venice. The dream which has not been accomplished will create a strong emotional bonding between prospects and Venice. Whenever prospects have purchase power and chance, they will put Venice on the top of the country they want to visit in their list.

An effective and intensive promotion will create an aspiration. This aspiration will encourage the creation of emotional bonding within prospects and the country

they want to visit.

Based on the explanation above, hypotheses three is proposed as follows:

H3: The better the promotion is, the stronger the emotional bonding between the prospect and the country they want to visit.

### **The Relationship between Promotion and Intention to Visit**

Previous research has showed that promotion influences purchasing intention (Minnini, 2005b; Haryanto, 2008; Santrock, 2001). Basically, prospects always have the intention to travel abroad. If advertisers stimulate and communicate this intention intensively, it will be a need and might create intention to visit the country. On the other hand, without promotion, the intention will not be stimulated well and will be a subconscious need without any manifestation (Santrock, 2001). That is why advertisers need to promote intensively to create the intention to visit in prospects.

This is applied by Singapore, which intensively communicate their events or special occasions, like "Singapore Great Sale" or "Christmas in Singapore". These kinds of promotions have proven to increase the number of visitor in Singapore significantly (Haryanto et al. 2005).

In a more formal language, a hypotheses is proposed as follows:

H4: The better the promotion is, the higher the intention to visit a country.

### **The Relationship Between Perception and Intention to Visit**

Prasetijo and Ihalaw (2003) stated that a good and positive perception of an object will create a positive consumer's evaluation. The same thing applied to negative perception. That's why it is important for the advertisers to pay attention to the process of perception creation in consumer's mind. Ries and trout (1986)



stated that consumer's perception mind is a battle field of advertisers through marketing communication aimed to achieve positive perception in consumer's mind. Research done by Sari (2008) for green product has proven that perception about the product's advantage influences significantly towards the intention of purchasing green product.

In tourism industry context, a positive perception towards a country, such as the beauty, culture, scenery, etc. will encourage prospects to visit the country.

Based on the descriptions above, a hypotheses is proposed as follows:

H5: The better prospect's perception of a country is the higher prospect's intention to visit the country.

#### **The Relationship between Autobiographical Memory and Intention to visit**

Research done by Haryanto (2008) showed that autobiographical memory influences significantly towards the intention to visit. Positive autobiographical memory will always be recorded as a positive memory in prospects' mind. If the necessity or intention emerges, prospects will subconsciously recall the label. The label in tourism context is the country which has a positive autobiographical memory according to the prospects (Rubin,2006).

Consumer's memory about branding or branding's experience when the consumer visits a country will have huge consequences into the next decision due to the emotional attachment which was established before. In this matter, autobiographical memory is perceived as a reliable record with strong visualization that would create an original experience.

Sutjan et al. (1993) showed that a positive autobiographical memory will lead to a positive attitude towards advertising and enhance the brand evaluation. When an autobiographical memory has been

developed, then it will influence prospects's choices or preferences (Bertsen and Rubin, 2002).

In relation to the product consuming, the positive or negative experience will be memorized strongly in the autobiographical memory. Positive experience when consuming products will stimulate prospects to consume the product again. Prospects with experience in consuming products and still want to consume again due to their satisfaction will memorize those things in their autobiographical memories. This experience will be memorized continuously and will drive to the intention to consume again.

Based on the descriptions above, a hypotheses is proposed as follows:

H6: The better the autobiographical memory created, the higher the intention to visit appears.

#### **The Relationship between Emotional Bonding and Intention to Visit**

The thesis that states a strong emotional bonding to a product, label, or country is a valuable asset for the advertiser, has been done by Solomon (2007) and Kotler and Keller (2006). A research done by Lindstorm and Seybold (2007) has proven that teenagers who are strongly bond with a product have a high tendency to use the same product constantly. This happens because each individual has a high resistance to try new products, so directly or indirectly, he/she tends to use the product that has an emotional bonding before (Micinnis and Park, 2005).

In tourism context, prospects also have high tendencies to visit the country where they have emotional bonding previously. This kind of bondage can be created through marketing communication, visiting experience, or from word-of-mouth. Therefore, it is important for the advertisers to establish an emotional

bonding to prospects before hand, so when the intention to travel appears, prospects will visit the country with an emotional bonding experience. In a formal language, a hypotheses is proposed as follows:

H7: The stronger the emotional bonding, the stronger the intention to visit is.

### Survey's Method

The data were collected via consumer surveys from two cities in Central Java. Because of the number of constructs in the model and the complex relationships among them, it is best to test it in two or more parts before testing the entire model. Before the empirical test, we have conducted an extensive qualitative research (focus group discussion and depth interviews) with 12 prospects in Jakarta as a first step to validate the questionnaires and to propose the model above.

This research would not only help to generate a list of constructs with which prospects are likely to identify but to develop new or refine existing measures of the model's key construct. We have also done some subject-matters with experts (2 tourism experts and 1 expert in marketing for tourism). This was done to use understandable language and questions for prospects. Prior to this empirical examination, however, pretests were conducted to validate our adaptations of existing scales.

### Pretest Study

Pretest study was conducted with 30 prospects in Salatiga, Central Java and 30 prospects in Semarang, Central Java. Measures were captured relative to intention to visit for tourism purposes. The aim of this pretest was to examine the scales that would be used to test the model.

The construct measurement used primarily existing scales, adapted for to

be examined prospects. To make prospects easier in answering the questions for the empirical testing, the measures using 6 points likert scale.

Results from the pretest showed that the reliability of all scales was adequate according to the Nunnally's (1978) standard. Some questions appeared to be problematic for the pretest respondents'. Their comments were reworded for the main study.

### Main Study

A database of prospects selected from Salatiga and Semarang. A final sample of 200 completed surveys was obtained. This research implemented convenience sampling in getting the respondents. In this research the researcher would like to identify the relationship between promotion and emotional bonding as well as the relationship between emotional bonding and intention to visit. Therefore, in this research the characteristics of the sample are as follows: (1) Their minimum expenditure is 5 million rupiah (approximately USD 450) per month (2) They have visited at least 3 overseas countries for tourism purpose (3) They paid their travel by themselves.

From the data, it could be seen that approximately 60 % of respondents were males, and the average of their expenditures were 5-10 million rupiah (approximately USD 450-950) per month. It appeared that a majority of the respondents go to abroad with their family and they spent 2-7 days there.

## Result and Discussion

Exploratory and confirmatory analyses were also conducted. First, exploratory principal component analysis (varimax rotation) and reliability analyses were performed to refine the scales. For all constructs, a one-dimensional structure was found.

Table 1. Scale Items and Measurements

Construct	Measurements
Promotion	If I would like to go abroad, I will choose to visit: (SD .. SA)
	(1) A country which held special events
	(2) A country with interesting tourism commercial
	(3) A country recommended by friends
	(4) A country with often appears in TV commercial
Perception of Country	(5) A country recommended by travel agents
	If I would like to go abroad, I will choose to visit: (SD .. SA)
	(6) A country with strict security
	(7) A clean country
	(8) A country with an organized infrastructure
Autobiographical Memory	(9) A country with adequate transportations
	(10) A country with beautiful view
	If I would like to go abroad, I will choose to visit: (SD .. SA)
	(11) A country that I have dreamed of visiting to
	(12) A country that my family often talks about
Emotional Bonding	(13) A country that my friends often talks about
	(14) A country that I've ever visited
	(15) A country that has a memory
	If I would like to go abroad, I will choose to visit: (SD .. SA)
	(16) A country which suits my character

A confirmatory factor analysis (CFA), using LISREL 8.73 with maximum-likelihood (ML) estimation (Joreskog and Sorbom, 1993), was then performed on the scales. To assess the structural model, multiple fit indexes are reported. For assessment, commonly used, fit indexes are reported: Goodness-of-Fit Index, root mean square error of approximation (RMSEA), Normed Fit Index (NFI), and Comparative Fit Index (CFI). Standardized data were used for all subsequent analyses. The process of standardization eliminates the bias introduced by the difference in the scales of the several attributes or variables used in the analysis (Hair, Anderson, Tatham, and Black, 1995). Overall model fit indexes indicated that the CFA model was consistent with the data, with all fit indexes equal to, or better than, recommended values (GFI=.88, RMSEA=.061, NFI=.94, CFI=.97, P value= .00, Standardized RMR = .067).

From the analysis above, some antecedents of intention to visit abroad are identified. The data shows that promotion influences country's perception significantly (H1 supported by data). This finding strengthen my hypothesis that promotion

which is done appropriately will enhance intention to visit for prospects. The methods of promotion itself could be advertising on television or print media, good web sites or internet marketing, and event marketing such as local or international event. If countries want to enhance the number of tourist, they have to create and develop a comprehensive promotion strategy (Darley and Lim, 1986; Braun et al. 2002).

Promotion influences autobiographical memory significantly (H2 supported by the data). A good promotion will be stored in prospects' memory, and whenever prospects have the intention to go abroad, they will make a recall toward their memory and select a country which they have good autobiographical memory before (Bernsten and Rubin, 2002). This means that effective promotion sometime does not give benefit directly, i.e. increased number of prospects significantly after the promotion was launched. On the other hand, promotion could create positive autobiographical memory and it functions as awareness (Rubin, 2006). If prospects have the intention to go abroad, they will go the country wherever they have awareness before.

Figure 2. Path Diagram

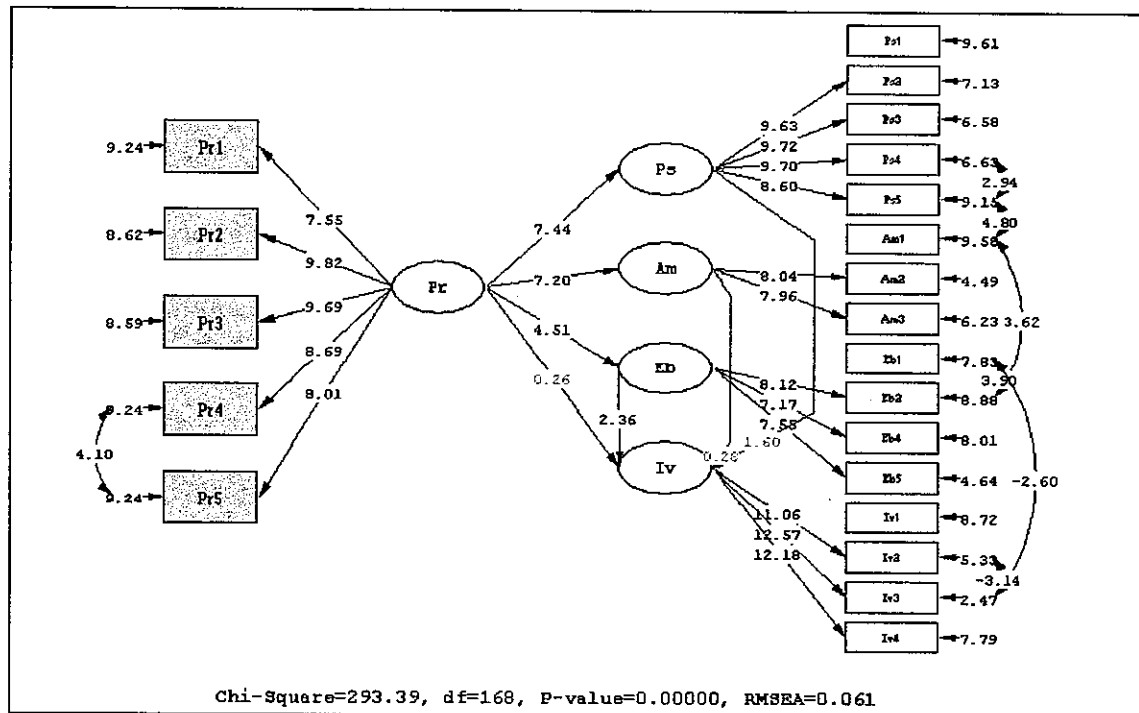

Promotion influences emotional bonding significantly (H3 supported by the data). Promotion which is done for target prospects will create a strong emotional bonding for prospects toward those countries. If the promotion done gives an impressive memory, and is recorded in prospect's autobiographical memory that makes a desire in them, then a strong emotional bonding is created in prospect, although he/she has never been there (Macinnis and Park, 2005). For example, an intensive promotion about the beauty of Venice, added with the romantic gondola trip through the rivers of Venice, makes so many youngsters dream about having their honeymoon in Venice. The dream which has not been accomplished will create a strong emotional bonding between prospects and Venice. Whenever prospects have purchase power and chance, they will put Venice on the top of the country they want to visit in their list. An effective and intensive promotion will create an aspiration. This aspiration will encourage the creation of emotional bonding within prospects and the

country they want to visit.

Promotion does not influence intention to visit significantly (H4 not supported by the data). This finding shows that promotion does not directly influence intention to visit. This could happen due to high involvement of prospects on selecting countries to go. Prospects usually search for information regarding target countries. They also absorb all the informations and promotions done by countries then store it first in their memory. This could explain why promotion does not significantly influence intention to visit. Furthermore, some of the respondents are under 21 years old (36%) which means that they do not have their own purchasing power so they are depended on family's choice about selecting the countries. This will make them answer that promotion does not significantly influence intention to visit.

Perception about country does not significantly influence intention to visit (H5 not supported by the data). Prospects visit the countries because of recommendations from tour agent or friends. Most of the

prospects do not visit same countries more than once. It means that their perception is developed by others and not by their own experiences. This will make them not too rely on their own perceptions. They will still visit a specific country if there are recommendations from their friends regardless poor country's infrastructure.

Autobiographical memory does not significantly influence intention to visit (H6 not supported by the data). Item of questions in autobiographical memory reflect intention to revisit. This could explain why autobiographical memory does not influence intention to revisit because usually people tend to visit a certain country only for one time. They will prefer countries that they never visit before. Thus, memory is used to push the intention to visit at the first time but could not push for the second visit. However, this memory will be storage for giving recommendations toward their families or friends.

Emotional bonding significantly influences intention to visit (H7 supported by the data). This means that prospects visit to a specific country is based on their emotional bonding (Sadock and Sadock, 2007; Luthje, 2004). A country which has special characters will make strong emotional bonding with prospects (Macinnis and Park, 2005). It is necessary for a country to develop specific characters which will make prospects falling in love with that country. Collaborations with movie producers such Hollywood (USA) or Bollywood (India) could lead prospects to have a strong emotional bonding with a country. Marketers could use product placement strategy in promoting their country through movie.

## Conclusion

Advertisers often pay no serious attention to manage unique and potential tourism

market. They only depend on word-of-mouth promotion without ever carrying out the proper promotion strategy. They often apply marketing approach for the company, whereas the approach has quite different basis with the tourism approach. This research is expected to give a contribution about the factors that influence prospect's intention to visit.

This research is looking forward to know the factors that mediate the relationship of promotion and visiting intention. Therefore, promotion is not only able to enhance purchasing intention these days, but also to aim at the autobiographical memory (long term memory based on previous experience) for the foundation of a potential future market. Eventhough autobiographical memory is not significantly influence intention to visit but if marketers are able to develop positive autobiographical memory than it will be stored as customer satisfaction which finally bring to patronage or positive word of mouth (Kumar, 2002; Lam, Shankar, Erramilli, and Murthy, 2004).

The data shows that emotional bonding play a vital role in stimulating intention to visit toward a specific country. Marketers have to develop serious marketing communication strategy in order to create and develop emotional bonding for prospects. This emotional bonding could be reached through collaboration with movie producers or push the promotion strategy continuously.

From the analysis above, it could be seen that promotion will significantly influence country's perception, autobiographical memory and emotional bonding. It is important for marketers to promote their country periodically in order to create awareness toward the promoted country. Marketers could use promotional mix, such as advertising (it has been conducted by Malaysia which advertises in most ASEAN countries), internet marketing, direct marketing (via exhibition), and public

relation. This kind of promotion strategies have to be managed carefully in order create a holistic promotion strategy. Indonesia which has many tourism destinations should show seriousness in developing tourism and it has to be announced via promotion.

### Limitations and Further Reseach

The sample which is taken for this reseach only come from two cities in Central Java, Indonesia. Next research could gain sample from more various cities around Indonesia or even in other countries. Some of the samples are teenagers who do not have their own purchasing power so their decision is basically determined by their families. However, in this reseach I assume that they have already had their decision

making processes.

Next research should be able to identify the antecedents of emotional bonding. This becomes important due to the vital role of emotional bonding in stimulating intention to visit toward a specific country. If the strong antecedents of emotional bonding could be identified, so marketers could create more appropriate marketing strategy.

In my reseach it could be seen that promotion influences country's perception, autobiographical memory and emotional bonding. However, the dominant factors which influence intention to visit is only emotional bonding. Next research should be able to recognize what kind of promotion strategy that could stimulate prospects to have intention to visit.

## References

- Bansal, H.S., Taylor, S.F., and James, Y.S. (2005), Migrating to New Service Providers: Toward a Unifying Framework of Consumers' Switching Behaviors, *Journal of the Academy of Marketing Science*, 33 (1), 96-115.
- Bearden, W.O., and Teel, J.E. (1983), Selected Determinants of Consumer Satisfaction and Complaint Reports, *Journal of Marketing Research*, 20 (February), 21-28.
- Braun, K.A., Ellis, R., and Loftus, E.F. (2002), Make My Memory: How Advertising can Change Our Memories of the Past, *Psychology and Marketing*, 19, (1), 41-70.
- Brahm, L.J. (2001), *China's Century*, Jakarta: Interaksara.
- Berntsen, D., and Rubin, D.C. (2002), Emotionally Charged Autobiographical Memories Across the Lifespan: The Recall of Happy, Sad, Traumatic, and Involuntary Memories, *Psychology and Aging*, 17, 636-652.
- Darley, W.F. and Lim, J.S. (1986), Family Decision Making in Leisure Time Activities: An Exploratory Investigation of the Impact of Locus of Control, Child Age Influence Factor and Parental Type on Perceived Child Influence, *Advances in Consumer Research*, 13, Richard J. Lutz (Ed.), Provo, UT: Association for Consumer Research, 370-375.
- Eberl, P. (2004), The Development of Trust and Implications for Organizational Design: A Game and Attribution Theoretical Framework, *Schmalenbach Business Review*, 56, 267.
- Evanschitzky, H., Iyer, G.R., Plassmann, H., Niessing, J., and Meffert, H. (2006), The Relative Strength of Affective Commitment in Securing Loyalty in Service Relationships, *Journal of Business Research*, 59, 1207-1213.
- Gunter, B., and Furnham, A. (1998), *Children as Consumers: A Psychological Analysis of the Young People's Market*, Routledge: London.

- Haryanto, J.O. (2008), Analisis Intensi Mengkonsumsi Lagi pada Anak dalam Membangun Kekuatan Mempengaruhi, Pembelian Impulsif dan Autobiographical Memory, *Dissertation*, Faculty of Economics University of Indonesia.
- Haryanto, J.O, Rahardjo, L., Timotius, R.W., Kusumo, S.A., and Purwati. Y. (2005), *Pengantar Manajemen Pemasaran*, Salatiga: Faculty of Economics Satya Wacana Christian University.
- Isler, L., Popper, E.T., and Ward, S. (1987), Children's Purchase Requests and Parental Responses: Results From A Diary Study, *Journal of Advertising Research*, 27 (October), 28-39.
- Kotler, P. and Keller, K.L. (2006), *Marketing Management*, 12<sup>th</sup> ed, New Jearsey: Pearson Prentice Hall.
- Kumar, P. (2002), The Impact of Performance, Cost, and Competitive Considerations on the Relationship Between Satisfaction and Repurchase Intent in Business Markets, *Journal of Service Research*, 5 (I): 55-68.
- Lam, S.Y., Shankar, V., Erramilli, M.K., and Murthy, B. (2004), Customer Value, Satisfaction, Loyalty, and Switching Costs: An Illustration From a Business-to-Business Service Context, *Journal of Academy of Marketing Science*, 32, 293-311.
- Levin, D.E., and Paige, N.C. (2003), Marketing Violence: The Special Toll on Young Children of Color, *The Journal of Negro Education*, 72 (4), 427-437.
- Lindstorm, M., and Seybold, P.B. (2007), *Top Brand Anak and Remaja*, Jakarta: PPM Publisher.
- Luthje, C. (2004), Characteristics of Innovating Users In a Consumer Goods: An Empirical Study of Sport-related Product Consumers, *Technovation*, 24, 683-695.
- Macinnis, J.C., and Park. J.O. (2005), Emotional Bonding as Determinants for Intention to Buy, *Journal Retail*, 62, 67-81.
- Mininni, T. (2005a), Kids Want it Cool and True, *Journal of Brand Identity and Consumer Promotion*, 64 (August), 64-73.
- Mininni, T. (2005b), Maintaining Brand Relevance With Kids, *Journal of Young Consumer*, 2, 23-36.
- Nunnally, J.C. (1978), *Psychometric Theory*, 2<sup>nd</sup> Ed, New York: McGraw-Hill.
- Oliver, R.L. (1996), *Satisfaction: A Behavioral Perspective on the Consumer*, New York: Irwin Mc-Graw Hill.
- Popper, A.H., and Ward, R.Jr. (1987), Determinants of Coordination Modes within Organization, *American Sociological Review*, 41 (2), 322-338
- Prasetijo, R., and Ihalauw, John, JOI. (2003), *Perilaku Konsumen*, Salatiga: Faculty of Economics Satya Wacana Christian University.
- Ries, Al, and Trout, Jack. (1986), *Marketing Warfare*, New York: Irwin McGraw Hill.
- Rook, D.W. (1987), The Buying Impulse, *Journal of Consumer Research*, 14, 189-199.
- Rook, D.W., and Fisher, R.J. (1995), Normative Influences on Impulse Buying Behavior, *Journal of Consumer Research*, 22, 305-313.
- Rubin, D. (2006), Autobiography Memory, *Journal of Child and Psychiatry*, 37, 286-329.
- Sadock, B.J., and Sadock, V.A. (2007), *Synopsis of Psychiatry*, New York: Lippincott Williams and Wilkins.
- Santrock, J.W. (2001), *Child Development*, New York: Irwin McGraw Hill, 9<sup>th</sup> Edition.
- Sari, H. (2008), Peran Produk Hijau dalam Edukasi Pelanggan dan Menciptakan Intensi Membeli, *Dissertation*, Faculty of Economics University of Indonesia.

- Solomon, M.R. (2007), *Consumer Behavior – Buying, Having and Being*, 7<sup>th</sup> ed., New Jersey: Pearson Prentice Hall.
- Sutjan, M., Bettman, J.R., and Baumgartner, H. (1993), Influencing Consumer Judgments Using Autobiographical Memories: A Self-referencing Perspective, *Journal of Marketing Research*, 30, 422-36.



