

11-2-2006

Determination of Operation Condition and Product Dimension Accuracy Optimization of Filament Deposition Modelling on Layer Manufacturing Application

Slamet A. Widyanto

Teknik Mesin, Fakultas Teknik, Universitas Gadjah Mada, Yogyakarta 55281, Indonesia, susilo70@yahoo.com

Alva Edy Tontowi

Teknik Mesin, Fakultas Teknik, Universitas Gadjah Mada, Yogyakarta 55281, Indonesia

Jamasri Jamasri

Teknik Mesin, Fakultas Teknik, Universitas Gadjah Mada, Yogyakarta 55281, Indonesia

Heru Santoso Budi Rochardjo

Teknik Mesin, Fakultas Teknik, Universitas Gadjah Mada, Yogyakarta 55281, Indonesia

Follow this and additional works at: <https://scholarhub.ui.ac.id/mjt>



Part of the [Chemical Engineering Commons](#), [Civil Engineering Commons](#), [Computer Engineering Commons](#), [Electrical and Electronics Commons](#), [Metallurgy Commons](#), [Ocean Engineering Commons](#), and the [Structural Engineering Commons](#)

Recommended Citation

Widyanto, Slamet A.; Tontowi, Alva Edy; Jamasri, Jamasri; and Rochardjo, Heru Santoso Budi (2006) "Determination of Operation Condition and Product Dimension Accuracy Optimization of Filament Deposition Modelling on Layer Manufacturing Application," *Makara Journal of Technology*. Vol. 10 : No. 2 , Article 6.

DOI: 10.7454/mst.v10i2.430

Available at: <https://scholarhub.ui.ac.id/mjt/vol10/iss2/6>

This Article is brought to you for free and open access by the Universitas Indonesia at UI Scholars Hub. It has been accepted for inclusion in Makara Journal of Technology by an authorized editor of UI Scholars Hub.

DETERMINATION OF OPERATION CONDITION AND PRODUCT DIMENSION ACCURACY OPTIMIZATION OF FILAMENT DEPOSITION MODELLING ON LAYER MANUFACTURING APPLICATION

S.A Widyanto, A.E Tontowi, Jamasri, dan Heru Santosa B.R

Teknik Mesin, Fakultas Teknik, Universitas Gadjah Mada, Yogyakarta 55281, Indonesia

E-mail: susilo70@yahoo.com

Abstract

Layer manufacturing process has proven as a process that can produce a high complexity mechanical part. Now, Improvement of LM methods continuously conduct that is aimed to increase precessions and efficiency of these processes. Pressure filament deposition modelling is a form of layer manufacturing process that is designed to produce a plastic part with controlling its semisolid phase. In this research, the equipment of filament depositor is designed and tested to make the product filament deposition. With operation condition observation, the optimal temperature and pressure of deposition process was determined. These experiments used PVC as crystalline material and polypropylene as amorphous material. To optimize this process, the tensile strength and density test were conducted. The shape of tensile test specimens is based on ASTM 638 standard and made in 3 orientations deposition path, namely: in 0 degree, 45 degree and 90 degree from load force axis. To found the most accurate dimension, controlling the time delay, temperature of build part, feeding speed and variation deposition path was conducted. The results of experiments show that the filament deposition method can only be applied for amorphous material in which it has a semisolid phase. From the tensile strength test, the binding strength among filaments is 0.5 kg/mm^2 , 20% of the tensile strength of filament. And the density of a sample product, which used the filament diameter of 0.8 mm, is 0.7668 g/cm^3 . Accuracy of product dimension can be increased by: controlling time delay in location where the motion orientation of hopper filament is changed and controlling temperature of build part surface.

Keywords: semi solid phase, deposition, filament flow-rate

1. Introduction

Layer manufacturing has proven as a process that can help to rapidly provide feedback on design concepts, discover inconsistencies in the design, modify the design, and eliminate inconsistency before fabricating the design. This greatly reduces the production cycle time, and tremendously contributes to quality, competitiveness, and reduction in maintenance cost [1]. Generally the layer manufacturing technology does not require pre-formed mandrel or tooling; instead, it builds physical objects directly from computer image data and it constructs the three dimensional object layer by layer [2].

Some techniques of layer manufacturing process had been developed. Beaman *et.al.*[2] had developed a Filament deposition method (FDM). The FDM system uses a resistively heated delivery head to melt thermoplastic wire-like filaments. Since this delivery head is x-y position controlled, the semi-molten filament can be deposited to the location where the object is to fabricated [1]. Tseng developed an adaptable

filament deposition (AFD). This technique used modification of FDM system, in which it was capable of depositing variable size of filaments in a controller manner [1]. In two years after, Tseng [3] developed a Planar Layer Deposition (PLD) that uses adjustable planar nozzle to deposit layers directly. Khalil *et. al.*[4] developed a biopolymer material deposition that used air pressure as a driver of flow. In his paper, he classified the mechanism of nozzle application in two types, namely: extrusion mode and droplet mode. The extrusion mode, material is flown out nozzle by pressure, while in droplet mode, material is deposited out from nozzle by controlling frequency function and the others setting parameters in nozzle system.

In this research, the equipment of filament depositor is designed and tested to make the product filament deposition. Raw material is a form of polypropylene and PVC pallets, in which this method is different to commonly filament deposition modelling which uses plastic filament as raw material. Parameters of this process, which consisted of nozzle diameter,

temperature operation, air pressure and deposition parameters were studied and optimized.

2. Theory of Glass Transition Temperature and Polypropylene Material Properties

Glass transition temperature. Glass transition temperature of material (T_g) is a temperature which molecules have little relative mobility. T_g is usually applicable to wholly or partially amorphous phases such as glasses and plastics. For inorganic material or mineral glasses, the mid-point of a temperature range in which they gradually become more viscous and change from being liquid to solid. Thermoplastic polymers are more complex because melting temperature, T_m above which all their crystalline structure disappears and T_g below which they become rigid and brittle, and can crack and shatter [5].

For polymer material, above T_g , non covalent bonds between the polymers chains become weak in comparison to thermal motion. T_g is often expressed as the temperature at which Gibbs free energy is such that the activation energy for the cooperative movement of some elements of the polymer is exceeded. Correlation between stiffness and temperature can be explained by Figure 1 [5].

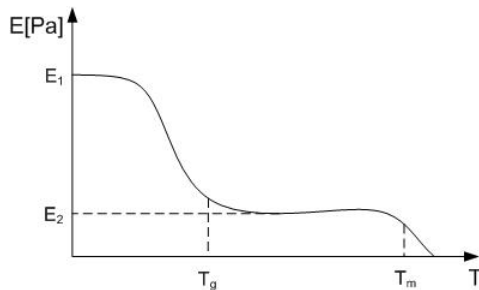

Figure 1. Correlation between modulus elasticity and temperature [5].

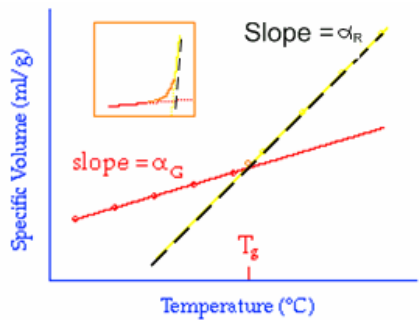

Figure 2. T_g can be determined by locating where the two lines intersect of α_G and α_R [6].

Table 1. Properties of polypropylene material [7].

Glass temperature transition	100°C
Specific Gravity (gr/23°C)	0.900 to 0.983
Melt mass flow (gr/10min)	0.27 to 50
Flexural modulus (psi)	152000 to 279000
Tensile strength (psi)	4270 to 6400
Tensile Elongation (%)	1.5 to 26
Rockwell hardness	89 to 110
Notched Izod Impact (ft-lb/in)	0.0400 to 1.39

T_g can also be corresponded with specific volume of material. Correlation between specific volume and temperature is presented in Figure 2. [6]. The T_g can be determined by locating where the two lines intersect, where α_G is the cubic volume expansion coefficient when the polymer is in the glassy state and α_R is the cubic volume expansion coefficient when the polymer is in the rubbery state.

Polypropylene material. Polypropylene (PP) is a thermoplastic polymer, of the chemical designation C_3H_6 , which used in a wide variety application. Polypropylene, which make from the monomer propylene, is unusually resistant to many chemical solvent, bases and acids, and it has also very good resistance to fatigue.

Melting point of polypropylene is higher than the other plastics, at 173°C and the density is 0.85 gr/cm³. The other properties of polypropylene (PP Homopoly) are presented in Table 1 [7].

3. Research Methodology

The research methodology consists of:

Deposition experiments. Deposition experiments were run by filament deposition machine which was constructed by system configuration in Figure 3.

With this machine, parameters of deposition process can be controlled. These parameters consist of deposition gap, feeding speed, temperature of build part and time delay (if needed).

Construction of hopper filament depositor. Hopper filament is equipment which is functioned to change the raw polypropylene material to be a semi-molten phase with pressure and heating process. Generally this construction consists of 5 parts, namely:

- Hopper as a material container
- Air pressure supply
- Heater system
- Isolating segment which used to anticipated the heat loose of heater system
- Nozzle system

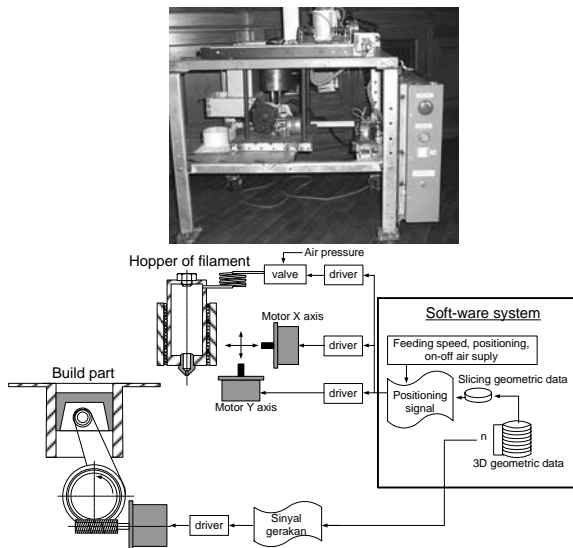

Figure 3. System configuration of filament deposition machine

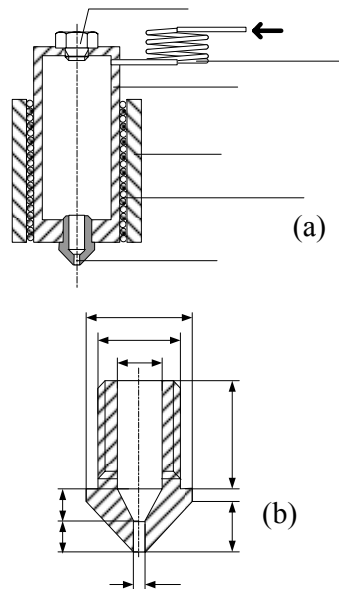

Figure 4. a) Construction of hopper filament, b) dimension of nozzle

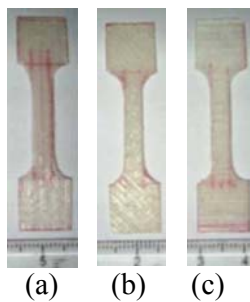

Figure 5. Tensile strength test specimens with varying orientation: a) 0°, b) 45°, c) 90°

Experiments. In this research, amorphous (polypropylene) and crystalline (PVC) materials were used in deposition experiments. With varying the parameters of filament flow which consist of temperature and nozzle's diameter, the optimal dimension of filament which flown out from the nozzle can be determined. Next, this result can be used as a basis on product making experiments.

When the product sample is made, varying the deposition parameters is conducted. These parameters consist of deposition gap, feeding speed, time delay and temperature of build part. To observe the mechanical and physical properties of the product, the tensile strength and density tests are run. The tensile strength specimens are based on ASTM-638 standard and made in variety orientation. With the tensile strength test of specimen with 90 degree orientation, the strength of binding among filament can be observed.

Product Dimension accurate Optimization. The accurate dimension optimization of product is conducted by experiments below:

- Applying the response time of filament flow such that the defect part due to discontinuity of it was neglected.
- Varying deposition path model on deposition experiment. This used 2 types of path models, namely open loop and close loop path model. These presents in Figure 6.
- Applying time delay on location where the orientation of hopper movement is altered.
- Controlling temperature of build part surface
- Controlling time delay for the altering layers.

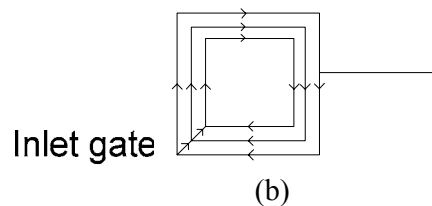
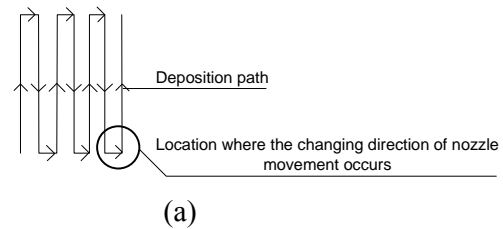

Figure 6. Deposition path model (a) open loop, (b) close loop

4. Result and Discussion

Filament Flow-rate

The initial research to develop the filament deposition modelling is to determine the parameter of filament flow. One of these parameters is a nozzle diameter of hopper filament. In process application, the nozzle dimension determines of filament diameter that means the product dimension accurate is depended on it.

With deposition experiment that used polypropylene material, the varying of nozzle's diameters could yield a continuous filament flow in pressure and temperature conditions. This presents in Table 2.

For nozzle diameter of 0.5 mm or 0.7mm, the varying air pressure, which was injected to hopper filament, could not affect to the filament flow-rate. The nominal filament flow-rate was being of 60 cm/min.

With filament deposition experiment, using each nozzle yields a filament which is shown in Figure 7.

Table 2. Pressure and temperature condition that yields a continuous filament flow

Nozzle's diameter	pressure	temperature
0.7 mm	10-20 psi	150 ⁰ C
0.5 mm	40 psi	150 ⁰ C

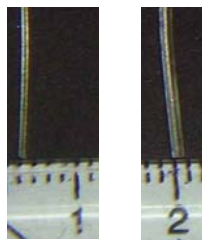

(a) (b)

Figure 7. Filaments which are yielded by nozzle's diameter: a) 0.5mm, b) 0.7mm

Table 3. The condition of PVC material as a temperature function

Temperature	The flow/phase condition
60 ⁰ C	Not flow
70 ⁰ -90 ⁰ C	PVC fluid drops and mixes to air
110 ⁰ -140 ⁰ C	PVC fluid Flows, Increasing temperature can enhance the flow-ability and decrease the viscosity.

On varying material experiments was found that the filament deposition can only be applied on amorphous material. With heating process, PVC could not yield a semi molten phase. Solid phase directly transformed to liquid phase if the melting point was passed. This condition was verified with temperature controlling and the result is presented in Table 3:

Mechanical and physical properties

The deposition path orientation of specimen affected its tensile strength. The binding strength among filaments which is found by tensile strength test for specimen with 90 degree orientation is 0.5 kg/mm², 20% of the tensile strength of filament. This is presented in Figure 8.

The density of a sample product, which used the filament diameter of 0.8 mm, is 0.7668 g/cm³. This can possibly be increased by using the smaller nozzle diameter on deposition process.

The accurately product dimension optimization

The accurately product dimension optimizations consist of:

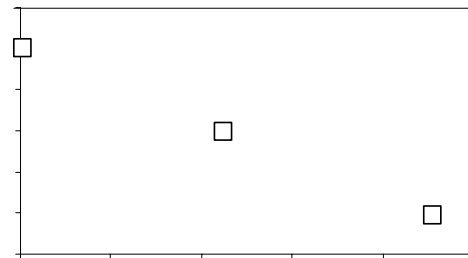
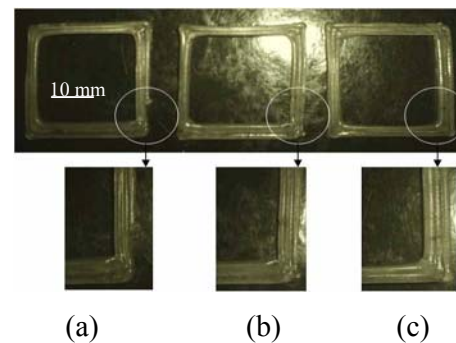

Figure 8. Correlation the tensile strength and its orientation



(a) (b) (c)

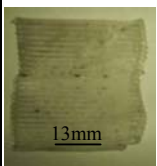
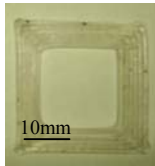

Figure 9. Applying response time of filament flow on deposition process, a) time delay of 300 ms, b) time delay of 1 s, c) time delay of 1.3 s

Applying response time of filament flow on deposition process. When the air valve of hopper filament is opened, filament is not flown directly. This causes an imperfectly product dimension, such that applying response time compensation in deposition process is needed. The Figure 9 shows the effect of applying response time decides the accurately product dimension.

Varying deposition path model. Deposition path model which used on deposition experiments consist of 2 types, namely open loop and close loop model. Comparison of product dimension which were resulted by each deposition path are presented in Table 4.

Accumulation of filament occurs on location where the motion direction of hopper nozzle is changed. Filament tends to follow the motion of hopper filament which is caused the cohesion force. With applying time delay on this location, filament has the enough time to stick to deposition surface (layers below). The longer of the time delay, the stick force of filament is stronger. But this effort must be considered because it caused the filament accumulation.

Table 4. Comparison of product dimension which were resulted by open loop and close loop deposition path

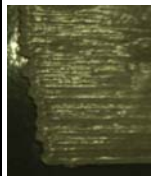
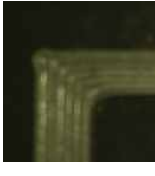
	OPEN LOOP	CLOSE LOOP
Applying Open loop deposition path caused un-accurate dimension on two sides of product where the motion orientation of hopper filament was changed		
Wrapping of product in cross section area which resulted by close loop deposition path is bigger than the one.		
Applying close loop deposition path caused accumulation of filament on the corner where the motion orientation of hopper filament is change, while the one, the accumulation of filament occurs on two sides of product dimension.		

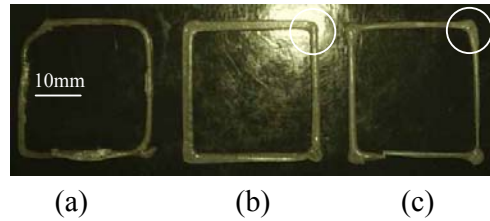

Figure 10. Applying time delay could increase an accuracy dimension in location where the motion orientation of hopper filament is changed, a) no time delay, b) time delay of 400 ms (in circle), c) time delay of 500 ms (in circle)

Varying the time delay on location where the orientation of nozzle motion is changed. The filament needs the time to move down and stick on the build part surface. This depends on the deposition gap. When the motion orientation of hopper filament is changed, the filament tends to take the shortest path. In this location is needed to apply the time delay.

Controlling temperature of build part surface. If the temperature difference between filament and build part surface is high, the filament could stick only in few times, around of 8 minutes, the next it will remove from the build part surface. This causes an error dimension when the deposition continuously conducted for the next layers.

By controlling temperature of build part surface, this condition could be solved. For polypropylene material, the optimal temperature is achieved on 100-110⁰C. This appropriate with it's glass transition temperature. The setting temperature higher than 110⁰C, the filament could not be solid, such that it could not strongly support the above layers.

Controlling time delay for process between altering layers. Controlling time delay is aimed to give the enough time of solidifying filaments before the next deposition process will run as above layer. Without time delay, the filament deposition as a currently layer will not be enough strong to support the above layers. This affects to the un-accurate product dimension on horizontal although vertical direction. From the experiments, the filament has been enough strong if the time delay is applied more than 25 sec.

Deposition experiments

The surface condition of filament deposition is depended on the diameter of filament (depend on nozzle diameter). Figure 10 and 11 show the surface condition of filament deposition part which used nozzle diameter of 0.5 mm and 0.7 mm respectively.

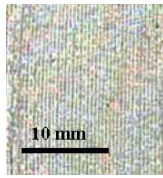

Figure 11. Surface condition of filament deposition part which was deposited by nozzle diameter of 0.5 mm, feeding speed of 30 cm/min

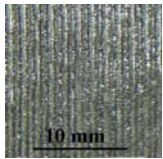

Figure 12. Surface condition of filament deposition part which was deposited by nozzle diameter of 0.7mm, feeding speed of 60 cm/min

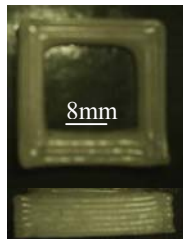

Figure 13. Multi layers deposition part which was deposited with close loop deposition path.

5. Conclusions

Filament deposition modelling could only be applied for amorphous material in which semisolid phase can be yield by increasing temperature if temperature achieved to T_{glass} (glass transition temperature).

For nozzle diameter of 0.5 mm or 0.7 mm, the filament flow is not influenced by air pressure which is injected to hopper filament. On varying air pressure, the filament flow-rate is a constant value around of 60 cm/min.

The binding strength among filaments which is found with 90 degree orientation is 0.5 kg/mm^2 , 20% of the tensile strength of filament. And the density of a sample product, which used the filament diameter of 0.8 mm, is 0.7668 g/cm^3 .

The accuracy dimension of filament deposition part can be increased by: controlling time delay in location where the motion orientation of hopper filament is changed, controlling time delay when the deposition process occurs the changing layer and controlling temperature of build part surface.

Reference

- [1] A. A. Tseng, US Appln. Serial No. 09/086,164, Submitted through Baker & Botts (A31685), 1998
- [2] J. J. Beaman, J. W. Barlow, D. L. Bourell, R. H. Crawford, H. L. Marcus, K. P. McAlea, Kluwer Academic, Boston, MA, 1997.
- [3] A. A. Tseng, US Patent No. 6030199, February 29, 2000.
- [4] S. Khalil, J. Nam, W. Sun, W, Rapid Prototyping Journal, 11(1) (1998) 9-17.
- [5] J. M. O'reilly, F.E. Karasz, J of Polym. Sci; Part C, 14 (1996) 49-68
- [6] R. D. Andrews, J of Polym, Sci; Part C, 14 (1966) 261-265
- [7] Ides, The plastic Web, 1986.