

12-3-2003

The Selection of Materials for Roller Chains From The Perspective Of Manufacturing Process

Rahmat Saptano

Departemen Teknik Metalurgi dan Material, Fakultas Teknik, Universitas Indonesia, Depok 16424, Indonesia, onot@eng.ui.ac.id

Follow this and additional works at: <https://scholarhub.ui.ac.id/mjt>



Part of the [Chemical Engineering Commons](#), [Civil Engineering Commons](#), [Computer Engineering Commons](#), [Electrical and Electronics Commons](#), [Metallurgy Commons](#), [Ocean Engineering Commons](#), and the [Structural Engineering Commons](#)

Recommended Citation

Saptano, Rahmat (2003) "The Selection of Materials for Roller Chains From The Perspective Of Manufacturing Process," *Makara Journal of Technology*. Vol. 7: Iss. 3, Article 6.

DOI: 10.7454/mst.v7i3.189

Available at: <https://scholarhub.ui.ac.id/mjt/vol7/iss3/6>

This Article is brought to you for free and open access by the Universitas Indonesia at UI Scholars Hub. It has been accepted for inclusion in Makara Journal of Technology by an authorized editor of UI Scholars Hub.

THE SELECTION OF MATERIALS FOR ROLLER CHAINS FROM THE PERSPECTIVE OF MANUFACTURING PROCESS

Rahmat Saptono

Departemen Teknik Metalurgi dan Material, Fakultas Teknik, Universitas Indonesia, Depok 16424, Indonesia

E-mail: *onot@eng.ui.ac.id*

Abstract

The selection of materials for an engineering component is not only requested by its design function and shape, but also the sequence through which it is manufactured. The manufacturing operation of roller chains involves drawing and trimming processes aimed at producing semi-finished chain drives component with a well-standardized dimension. In addition to final combination of properties required by design constraints, the ability of materials to be formed into a desired shape and geometry without failure is also critical. The objective of materials selection should therefore involve additional attributes that are not typically accommodated by the standard procedure of materials selection. The present paper deals with the selection of materials for roller chains from the perspective of manufacturing process. Ears and un-uniform wall thickness have been identified as a key problem in the mass production of component. Provided all process parameters were established, the anisotropy factor of materials is critical. Simulative test can be reasonably used to obtain material performance indices that can be added up to the standard procedure of material selection. Of three commercially available steel grades evaluated with regard to the criteria defined, one grade is more suitable for the present objective.

Keywords: roller chains, materials selection, manufacture, drawing, trimming, ears.

1. Introduction

The selection of materials is a critical stage in product development and manufacturing of engineering component. Vast materials processes available and enormous varieties of design requirements have been identified as the root of the problems in materials selection that challenges engineer [1]. From the manufacturing perspective, the sequence through which the component is manufactured is considered more critical than design requirement. Therefore, the selection process is not only determined by its function and shape, but also by the manufacturing process [1-3].

In addition to the final properties required by the design constraints, the technological properties of materials, that are the ability of materials to be formed and shaped into a desired shape and geometry without failure, is critical. The objective of materials selection should therefore involve additional attributes that have not been accommodated by the typical procedure of materials selection. Moreover, the assessment method should also be carefully designed and selected based upon the characteristic of forming process and the availability of the resources.

The present paper deals with the selection of materials for roller chains from the perspective of manufacturing process with particular reference to metal forming operation. Materials performance index and assessment method, which are more reasonable for the manufacturing process, together with more systematic and logical weighting, scoring, and ranking are proposed in this paper.

The essential characteristic of chain drives comprises a constant ratio, long life, and the ability to drive a number of shafts from a single source of power [4]. Of important is the angle of articulation that controls the cyclic impact load endured by the rollers and hence the wears of the chain joint. It is also known that the wear resistance and surface fatigue strength of the roller chains chiefly affect the actual life of a well-selected drive.

The shape and geometry of roller chains are standardized to maintain their function. The standard nomenclature of roller chains are depicted in Figure 1 [4].

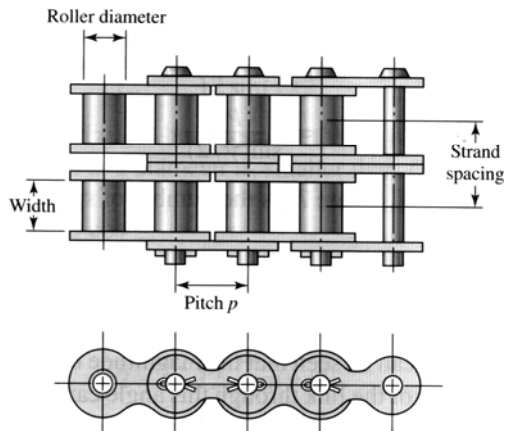

Figure 1. The standard nomenclature of roller chains in a double strand [4].

Typical design of roller chain for particular engineering applications, as reviewed in reference [4], had been published in many professional literatures as well as technical standards and publications. Further discussion about this topic, however, is beyond the scope of this paper.

The manufacturing process of roller chains, which involves metal forming processes, is mainly aimed at producing semi-finished product with a well-standardized geometry. The subsequent treatments, which are used to control the fatigue strength and wear resistance of the final product is not going to be discussed in this paper.

Metal forming is typically aimed at producing a part of desired shape and geometry without failure. With particular reference to roller chains, the dimensional accuracy and its consistency are intently desired. It was revealed in reference [5] that the dimensional accuracy may be affected by the thickness variation of work metal, the variation in work metals condition (mainly hardness), drawing technique (particularly the number of operations), tools accuracy, tools wear rate, and press condition. Provided the thickness variation is controlled and all process parameters are well established, the technological property of work metals is very critical.

Forming operations of complex component may involve various types of deformation that occurs simultaneously. The mass production of small parts with well-standardized geometry and high dimensional tolerance is usually performed in a progressive dies for some technical and non-technical reasons [5-7]. Typical sequence of forming processes of a small ferrule shape in progressive dies is illustrated in Figure 2 [5].

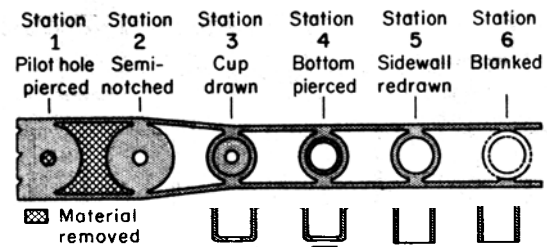

Figure 2. The example of forming processes in a progressive dies [5].

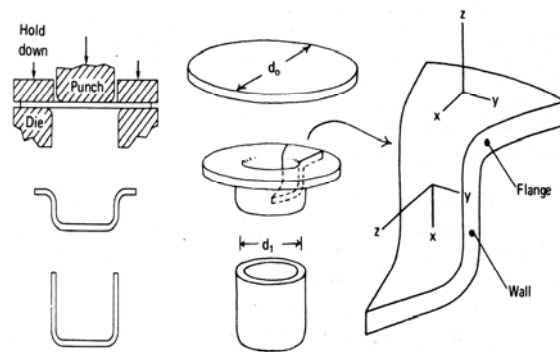

Figure 3. The schematic diagram of drawing process [8].

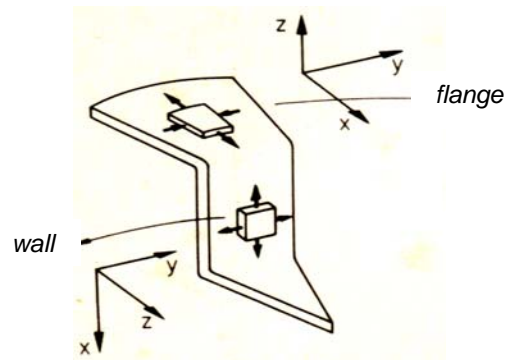

Figure 4. The schematic diagram of stress systems in a drawing operation [6].

It can be analyzed from final geometry that the process might be categorized as “a process in which a flat blank is constrained while the central portion of the sheet is pressed into the desired shape without folding the corners” [5].

The forming process of roller chains might be idealized by assuming that only one type of deformation occurs.

The key problems that might be identified from the appearance of drawn products are dimensional inaccuracy, ears formation, and variation of wall-thickness.

The schematic of the drawing process and the important stress systems working in the flange and cup wall are depicted in Figure 3 [8] and Figure 4 [6].

Required properties for the process can be derived from the diagram, as reviewed in reference [9]. The dominant stress system is radial tension combined with circumferential compression in the drawing region, while that in the base and lower cup wall is biaxial tension centered at the lower cup wall. This stress is equivalent to a through thickness compression in addition to hydrostatic stress that does not involve the state of yielding. The failure of drawing take places when the central stretch-forming zone is not strong enough to withstand the load required to draw the outer region of the blank through the die. Hence, the differential levels of strength in these two regions lead to easier deformation in the drawing region compared to stretching region would enable greater blank to be drawn.

It is concluded from the stress elements analysis of component in flange and wall that the strength of material in through-thickness direction relative to the strength in the plane of sheet plays important role. The variation in properties between plane and normal directions of sheet or normal isotropy measured by the ratio between the width and thickness strain is desired because it reduces wall thinning and drawing load [5,6,8-10]. The variation of normal anisotropy in the plane directions or planar anisotropy, however, is unwanted since it produces undesirable ears and wall thickness variations that require additional manufacturing process.

The ideal sheet for deep drawing should therefore have high normal anisotropy value combined with minimum planar anisotropy value.

It was revealed in reference [5] that the dimensional accuracy might be achieved through minimizing the variation of work metal condition. In addition to the thickness uniformity, the intrinsic properties of work metals must also be uniform to assure the uniform distribution of strain. Three materials properties are known affecting the distribution of strain [10]. They are strain hardening coefficient (n), the strain rate sensitivity (m), and the plastic strain ratio (r).

Grain sizes and surface finish may also influence drawability, particularly on low carbon sheet steels

[5,11]. Not only does promote excessive surface roughness, coarse grain ($>$ ASTM 5) may also reduce drawability. Dull surface of the sheet is considered beneficial due to its capacity of holding lubricant, improving drawability.

It can be learnt from previous analysis that the anisotropy of materials is most important in the manufacturing process. Either fundamental intrinsic or simulative test can be used to reveal the anisotropy of materials. The procedure of conventional tension testing is usually time-consuming and unreasonable, particularly for thin specimen [6,10-12]. New methods and apparatus have been developed to overcome these problems but not yet applicable [11]. Simulative tests, on the contrary, are more useful, more relevant, and closer to the production process.

A simulative test, which is particularly performed in laboratory, can be designed and selected from the various standards of simulative test based upon a definite purpose. For drawing process, Swift cup test [5,6,8,10,12] is one of the most appropriate standards. The test however, has to be performed under prudently controlled condition to minimize the variability of the result.

It is known from previous experimental works, as reviewed in reference [6,8-10,13], that the ratio of the largest blank that can be completely drawn without failure, Limiting Draw Ratio (LDR) is a function of the average value of normal anisotropy index r . The mathematical analysis that relates the LDR to the average strain ratio, r , which was largely performed by Whiteley, was reviewed in reference [8].

It was also revealed in reference [6] that the height of ears increases proportionally with the increase of planar anisotropy as large as 15-20% from the height of cup. The mechanical properties variation in the plane direction has not been reported influencing the ears formation. The effect of process parameters has not yet been reported existed in steel. The tools geometry and drawing process were only reported to influence the ears formation in the first draw of aluminum sheet.

Based upon these facts, more practical method was developed to measure planar anisotropy, by measuring the ears height on a standard cup and expressing the index as the percentage of the mean height [6,12]. It may be assumed that the percentage of ears, known as Willis and Blade index, is directly related to the planar anisotropy of materials. Additional information might also be acquired from this simulative test.

2. Experiment

Three grades of steel strips produced by conventional process were labeled as Material A, Material B, and Material C. Deep drawing simulative test was performed using the following conditions: 2 mm blank diameter interval (hand-cut), 40 mm diameter flat bottom cylinder, 42.5 mm diameter dies, oiled polyethylene lubrication, 1500 kg-f blank holder force, and fast punch speed. Stretching simulative test was carried out using 45 mm diameter hemispherical dome, oiled polyethylene lubrication, maximum clamping force (no material flow), and fast punch speed.

Limiting Drawing Ratio, LDR is calculated from the ratio between the blank diameter of successful cup, D , and punch diameter, d .

$$LDR = \frac{D}{d} \quad (1)$$

The minimum height of the wall, h_{\min} , as well as the maximum one are readily measured from drawn specimen and the percentage of ears is quantified using the following formula [6,12]:

$$\% Ears = \frac{(h_{\max} - h_{\min})}{\frac{1}{2}(h_{\max} + h_{\min})} \times 100\% \quad (2)$$

Limiting Dome Height, LDH is measured directly from the stretching test. Direct measurement of both stretched specimen dome height and punch displacement indicator is performed.

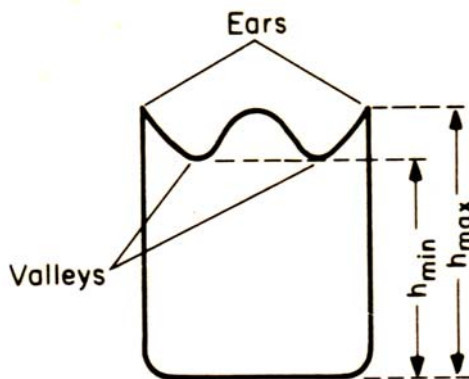

Figure 5. The schematic diagram of deep drawn component with ears due to planar anisotropy [6].

3. Results and Discussion

Table 1 displays important material attributes that were obtained from simulative test.

Simulative test, although requires carefully controlled condition, is more reasonable to be employed for some reasons. First, the method can be set up to approximate such process parameters as lubrication and speed. Second, the test is more efficient in term of time and cost. Last, the result of the test can also be well quantified, providing such important parameters as h_{\min} , the percentage of ears, LDR, and LDH that are more readily interpreted.

The minimum height of cup, h_{\min} directly measures that can be actually utilized after the trimming process. The percentage of ears, % ears proposed by Willis and Blade can be directly related to the planar anisotropy of materials as revealed in the literature review. The Limiting Draw Ratio, LDR is proportionally related to the normal anisotropy of materials as revealed in the previous reviews. The Limiting Dome Height, LDH, although is more related to stretching process, might be required due to the complexity of the process in which the stretching mode might also simultaneously contribute.

The materials performance index for manufacturing may be summarized as follow:

$$M \propto \frac{h_{\min} \times LDR \times LDH}{\% Ears} \quad (3)$$

Where, M is the materials performance index.

It is clear that the materials selection objective is to maximize the h_{\min} , LDR, and LDH, while minimizing the %Ears. This index might be combined with the standard materials selection objective.

The critical task in the selection stage is to decide the priority factor of the materials attributes acquired from the simulative test that will use to score and rank the

Table 1. Attributes related to manufacturing process obtained from simulative testing.

Materials	h-min. (mm)	Ears (%)	LDR	LDH (mm)
A	29.0	11.56	2.05	2.65
B	39.1	9.90	2.175	2.95
C	35.0	19.35	2.20	3.23

materials. Since the materials selection procedure should limit the subjectivity in the decision making process [1], the present discussion attempts to quantify the materials attributes by considering their relevance and importance.

It is known that the anisotropy planar is the most important materials attributes that can be directly related to the formation of ears in the simulative testing, using the percentage of ears known as Willis and Blade index. From industrial viewpoint, however, the minimum height of cup, h_{min} , is more readily interpreted since it is a direct representation of the height of the cup that can be actually utilized. Those attributes are more important than the Limiting Draw Ratio, LDR that does not provide any information about the useful height of cup. The optional attributes that both less relevant and important is the Limited Dome Height, LDH.

Weighting factors were also able to be reasonably determined. The rank of ordering was performed using a digital logic approach whereas the weighting factor of each property was determined proportionally to the number of positive responses, m_i [3].

$$w_i = \frac{m_i}{N} \quad (4)$$

$$N = \frac{n(n-1)}{2} \quad (5)$$

Where: n is the number of properties under consideration

The decision making table of ranking and weighting was set up.

Simple tabulation was performed to quantify the materials attributes, scoring and ranking materials based on defined assumption. The result is summarized in Table 2.

Table 2. The Rank of Candidate Materials

Materials	Score	Rank
A	0.19	2
B	0.24	1
C	0.18	3

4. Conclusion

The manufacturing process has to be involved in the selection of materials for engineering component. The term of materials selection for manufacturing might be used specifically comparable to that of DFM or design for manufacturing.

The objective of materials selection for roller chains manufacturing process is to produce well-standardized shape and geometry.

It is known from the analysis that the manufacturing process involves drawing and trimming and the formation of ears and un-uniform wall thickness were identified as key problems.

Provided all process parameters were established, plastic anisotropy is critical. Simulative test can be reasonably used to provide material attributes ($h_{minimum}$, % Ears, LDR, and LDH) that can be added up to the standard material selection procedure.

Of three commercially available steel grades evaluated with regard to the criteria defined, one grade is more suitable for the present objective

References

- [1] Y. Bretchet, D. Basetti, D. Landru, L. Salvo, Progress in Materials Science 46 (2000) 407.
- [2] Michael F. Ashby, Materials Selection in Mechanical Design, 2nd ed., Butterworth Heinemann, Oxford, 1999, p.13
- [3] George E. Dieter, Engineering Design, Materials and Processing Approach 2nd ed., McGraw-Hill, Inc., Singapore, 1991, p.273, p.149
- [4] Joseph E. Shigley, Charles R. Mischke, Mechanical Engineering Design, 6th ed., McGraw-Hill International Edition, Singapore, 2001, p.1079.
- [5] American Society for Metals, ASM Handbook Vol. 14: Forming and Forging, 9th ed., ASM International, Ohio, 1985, p.575.
- [6] Kurt Lange (Ed.), Handbook of Metal Forming. McGraw-Hill Book Co., New York, 1985, p.20.1.
- [7] O.D Lascoe, Handbook of Fabrication Processes, ASM International, Ohio, 1988, p.201.
- [8] William F. Hosford, Robert M. Caddel, Metal Forming: Mechanics and Metallurgy, Prentice Hall, New Jersey, 1983. p.263, p.274.

- [9] R.E. Smallman, R.J. Bishop, *Metals and Materials: Science, Process, and Application*, 1st ed. Butterworth-Heinemann Ltd., London, 1995, p.244.
- [10] American Society for Metals, *ASM Handbook Vol.14: Forming and Forging*, 9th ed., ASM International, Ohio, 1985, p.877.
- [11] K.P Rao, Emani V.R. Mohan, *Journal of Materials Processing Technology* 118, (2001) 238.
- [12] J.N. Harris, *Mechanical Working of Metals: Theory and Practice*, 1st ed., Pergamon Press Ltd. Oxford, 1983, p.225.
- [13] G.E. Dieter, *Mechanical Metallurgy*, 2nd ed. McGraw-Hill International Book Company, Singapore, 1981, p.688.