

4-30-2017

The Role of Business Sustainability in Human Resource Management: A Study on Indian Manufacturing Companies

Vasanth Lakshmi R.

Research Scholar, IBMT B-School, Bangalore, India, Vasanthlakshmi145@yahoo.com

Dr. Hanuman Kennedy

Professor, Dept of Management Studies, Christ University, Bangalore, India, hanumankennedy@gmail.com

Follow this and additional works at: <https://scholarhub.ui.ac.id/seam>



Part of the [Management Information Systems Commons](#), and the [Management Sciences and Quantitative Methods Commons](#)

Recommended Citation

R., Vasanth Lakshmi and Kennedy, Dr. Hanuman (2017) "The Role of Business Sustainability in Human Resource Management: A Study on Indian Manufacturing Companies," *The South East Asian Journal of Management*: Vol. 11 : No. 1 , Article 5.

DOI: 10.21002/seam.v11i1.7739

Available at: <https://scholarhub.ui.ac.id/seam/vol11/iss1/5>

This Article is brought to you for free and open access by UI Scholars Hub. It has been accepted for inclusion in The South East Asian Journal of Management by an authorized editor of UI Scholars Hub.

THE ROLE OF BUSINESS SUSTAINABILITY IN HUMAN RESOURCE MANAGEMENT: A STUDY ON INDIAN MANUFACTURING COMPANIES

Vasantha Lakshmi R

1Research Scholar, IBMT B-School
Bangalore, India
Vasanthalskhmi145@yahoo.com

Dr. Hanuman Kennedy

Professor, Dept of Management Studies,
Christ University, Bangalore, India
hanumankennedy@gmail.com

Abstract

Business sustainability from the point of view of human resource management (HRM) is a management and leadership philosophy about how people are most enable to contribute to success at their work by minimizing the negative impact of their work on the environmental and social factors and at the same time improving the financial factors in the organizations. This study is an empirical study conducted on 233 Indian manufacturing firms operating in the Karnataka region to investigate the role for HRM in business sustainability. The role for HRM in business sustainability is studied with the construct HRM strategic integration in business sustainability strategy. Further, this study focuses on the way HRM incorporates sustainability in its practices in the organization and its impact on the organizational performance. The data are analyzed using SEM, and the results revealed the significance of the relationship of the HRM strategic integration of sustainability strategy with the organizational performance. The organizational performance studied with respect to the three factors of business sustainability viz., profit, people, and planet. Further, these relationships are tested with contingency factors, age of the firm, and the number of employees for its significance in this relation. The empirical evidence of the study shows a significant positive relation of organizational performance when HRM has strategic integration in business sustainability strategy. Model I4C is derived to show the role for HRM in business sustainability.

Abstrak

Key Words: Sustainability, human resource, organizational performance, I4C model

Keberlanjutan bisnis dilihat dari sudut pandang manajemen sumber daya manusia (SDM adalah tentang bagaimana karyawan secara maksimal berhasil dalam melaksanakan tugasnya dengan meminimalkan dampak negatif dari faktor lingkungan dan sosial serta pada saat yang sama memperbaiki faktor keuangan perusahaan. Penelitian ini merupakan studi empiris yang dilakukan pada 233 perusahaan manufaktur India yang beroperasi di wilayah Karnataka untuk menyelidiki peran SDM dalam keberlanjutan bisnis. Peran SDM dalam keberlanjutan bisnis dipelajari dengan membangun integrasi strategis SDM dalam strategi keberlanjutan bisnis. Selanjutnya, penelitian ini berfokus pada

cara SDM memasukkan keberlanjutan dalam praktiknya dalam organisasi dan pengaruhnya terhadap kinerja organisasi. Data dianalisis dengan menggunakan Structural Equation Modeling (SEM). Hasil penelitian menunjukkan signifikansi hubungan strategi keberlanjutan organisasi dengan kinerja organisasi. Kinerja organisasi diukur melalui tiga faktor keberlanjutan bisnis yaitu, keuntungan, manusia, dan planet. Selanjutnya, hubungan ini diuji dengan faktor kontingensi, usia perusahaan, dan jumlah karyawan. Bukti empiris penelitian menunjukkan hubungan positif yang signifikan antara kinerja organisasi ketika SDM perusahaan memiliki integrasi strategis dalam strategi keberlanjutan bisnis. Model I4C diturunkan untuk menunjukkan peran SDM dalam keberlanjutan bisnis.

Kata kunci: Keberlanjutan, sumber daya manusia, kinerja organisasi, model I4C

The concept of sustainability—meeting today’s needs without jeopardizing the ability of future generations to meet their needs (WCED, 1987)—is penetrating board rooms across multiple industries (Kiron, 2012); this concept is now discussed in leading business journals like the Harvard Business Review and the MIT Sloan Management Review. As a major driver of business innovation and competitive advantage (Prahalad et al., 2009), sustainability is increasingly influencing business value and business decisions. Hence, the changing global environment is challenging companies to look beyond financial performance and include environmental and social values to drive their business.

In human resource management research and practice, the concept of sustainability has been predominantly used to refer to organizational performance—specifically to how high-performing individuals and high-performance working translates into performance that is sustainable over a long time (Parkes & Borland, 2012). However, more challenging issues are under wider debate in regards to sustainability. According to the Living Planet Report (World Wildlife Fund, 2010; Parkes & Borland, 2012). The

consumption level of humanity is now at a rate of 50% higher than the Earth can regenerate sustainably. It is also revealed that it takes more than a year and a half for the Earth to produce the resources we use in single year, and we need the capacity of two more Earths by 2030 to keep up with natural resources consumption level and absorb CO2 waste. Almost three planets are estimated to be needed by 2050. This raises many questions about the existing business models and practices and also the implications for business strategy and leadership, including both opportunities and threats. The business and academic communities are beginning to embrace these challenges; the contribution of HRM, however, seems limited. However, if we try to move to a more sustainable world, all actors need to be involved. In organizational context, the impact of businesses on the natural environment comes through the choices of raw materials and suppliers, land use, geographic locations, manufacturing processes, including creation of waste and pollution, organizational structures, financial arrangements, management systems, employment and work practices, customer services, community activities, use of information, and much

more. Therefore creating a sustainable society must involve changes to businesses. In an organization, human resource management is typically placed to provide leadership, drive, and innovation. HRM in an organization influences the individuals, groups, and all organizational actors to demonstrate sustainable attitudes and behavior. These in turn transform the businesses toward a sustainable future (Jackson, 2011; Renwick et al., 2011).

LITERATURE REVIEW

Several studies reveal that, irrespective of the size, age, and type of the business, sustainability is a must-have strategy and a competitive advantage for a firm. Sustainability in business with a firm's performance link is widely published information. At the same time, it is evident that HRM practices in business have a direct link with organizational performance. Parallel to these, several papers also reveal the link of HRM and sustainability. These papers form a basis for our study to find the role for HRM in business sustainability. Literature review of the selected articles related to these links is as follows.

Business Sustainability and Organizational Performance

Various researchers have revealed advantages of sustainability for business, namely through brand reputation, gaining investor confidence, increased financial performance, highly attractive to talent, influence environmentally conscious customers, revenue growth, managing costs, and, more important, complying with the legal and regulatory requirements (Strandberg Consulting, 2009).

The UN Global Compact and Accenture CEO study on sustainability 2013 and 2014 are the world's largest CEO studies on sustainability to the present of more than 1,000 top executives from 27 industries across 103 countries, which assessed the past, present, and future of sustainability in business-reported sustainability strategies and is a must-have strategy for businesses of all types and size invariably.

International sustainability surveys reveal a significant gap between those organizations that have fully embraced sustainability and those that do not. Those who are adopting it more gradually and in a more peripheral way, too, are experiencing the gap. Most organizations now recognize the business benefits of sustainability. The more "cautious adopters" are struggling to measure these and are not yet gaining a competitive advantage. Among the organizations that have successfully adopted sustainability in a strategic way, the reported benefits include greater efficiencies, the ability to innovate, increased profits, and business growth.

HRM and Organizational Performance

A number of researchers published a link of the HRM practices with some influential variables seeming to contribute positively to firm performance (Youndt et al., 1996). Studies revealed that interaction between business strategy and HRM practices is an important factor in organizational effectiveness. HRM-P link is widely studied, as in the most cited papers, thus research papers linking the contribution of policies and practices HRM and its impact on the

organizational performance (HRM-P link) (Paauwe, 2009).

Based on the contingency theory, human resource management strategy would be more effective, when the HRM strategies are appropriately integrated with a specific organizational and environmental context. Accordingly, the organizations that closely coordinate their business strategy and HRM strategy achieve better performance outcomes in comparison to organizations that do not (Asta & Zivile, 2012). The resource-based view provides the “inside out” perspective to gain a competitive advantage through human resources, and the AMO frameworks provides the outcome of this human resources, which has significant influence on the strategic objective of the organization.

The report from Boston Consulting Group and the World Federation of People Management Associations revealed that the greatest correlation between positive economic performance and skilled human resource practices such as leadership development on boarding of newly hired employees, performance management and rewards, recruiting and talent management, employee retention, and employer branding.

The Research Report (Schramm, 2012) shows just how big of a difference effective HR practices can make: “Companies that is highly skilled in core HR practices experience up to thrice the revenue growth and as much as twice the profit margins of less capable companies.” The pioneers in the systematic empirical studies of the HRM and performance link and the most cited articles in this area are by Huselid in 1995.

These many years saw a huge number of studies in different industries and different countries. Most of the literature seems to accept that HRM practices have a significant impact on organizational performance (Savaneviciene & Stankeviciute, 2012). The study by Lee, F-H, Wu (2010) also shows HRM practices contribute to improve firm performance.

Sustainability and HRM

Several researches on sustainability leadership reveal that HRM plays a major role in bringing sustainability culture to an organization. Research on leadership for sustainability, in the paper (Barry & Kurucz, 2012) Three Conceptions of the Triple Bottom Line: The Business Sustainability Role for HRM, revealed there is a key role for the HR function to play in helping to generate dialogue and build consensus on the sustainability intent and building alignment capabilities to help realize that intent.

The global community is unanimous in its thinking that sustainability is the only way forward for successful business enterprises and for the future survival of human civilization. Sustainable business models and sustainable business practices can make their companies more competitive in the emerging global economy. It is a growing priority for businesses of all types and sizes. In order to incorporate sustainability in business, HRM plays a significant role (KMPG, 2013).

Sustainability in business practices are through an iterative process for embedding sustainability values, understanding and engaging HRM stakeholders, reviewing and developing HRM policies and practices, and

tracking and reporting performance and effects. Through these processes, HRM will demonstrate how its sustainability performance aligns with leading global frameworks and supports overall business sustainability strategy (Rishikesha, 2005).

This emerging concept of sustainability in HRM practices has important implications both for organizational performance and for the HRM functions. HRM must support the development and implementation of corporate/business sustainability strategies because the unique contributions of the HR are critical to the success of the business. HRM must recognize the new sustainability context of organizations and align its practices. HRM needs to provide solutions for sustainable organization as well as manage the HRM function in a sustainable way.

Organizations may embark on the sustainability journey from different starting points and may even have different endpoints or objectives in mind. However, the development of sustainability comprises many common elements that apply across sectors and organizational types and that are relevant to forming a sustainability strategy and program.

According to a growing body of research, many employers are struggling to incorporate sustainability in a strategic way into their business and agree that HRM has a significant role to play in incorporating sustainability practices in an organization (Schroeder, 2012).

Research by Wirtenberg et al. (2012) highlights the role for HRM in incorporating sustainability in the

organization. As per this research, the HR function appeared to be actively involved and contributed to a wide spectrum of activities across the companies under study, although the specifics varied greatly from firm to firm. More specifically, the HR function was making meaningful contributions.

The aim of the research is as follows:

1. Reveal HRM strategic integration in business sustainability strategy as the role for HRM in an organization and its impact on the organizational performance.
2. Further, study HRM integration through the formulation and implementation of sustainability strategy in HRM practices. That is, sustainability incorporated HRM practices at the content level through the functions of HRM (recruitment and selection, training and development, performance management and employee engagement).
3. Derive a model for the role for HRM in business sustainability.

RESEARCH FRAMEWORK

Operational Model and Hypotheses

Every organization, in order to achieve its business objectives, formulates business strategies at a corporate level, a unit/business level, and a functional level. This strategy may be written or unwritten depending on the culture of the organization, but the ultimate success depends on how best these strategies translate in the business processes being implemented.

It is evident that more and more businesses are embracing the sustainability strategy to gain

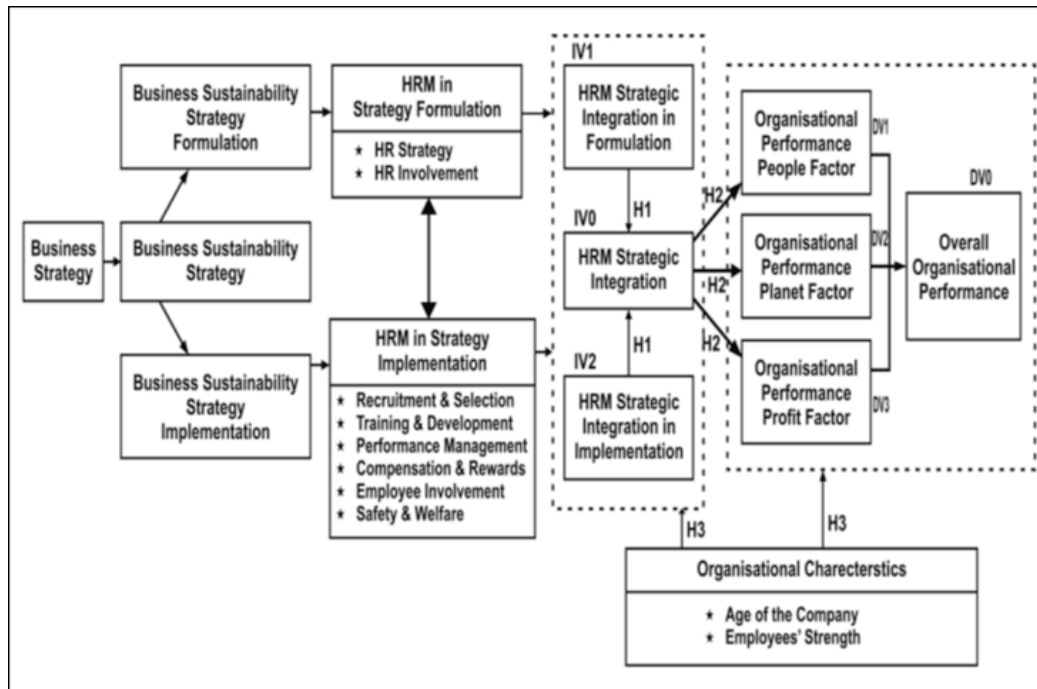

Figure 3.1. Operational model: Business sustainability role for HRM

the competitive advantage. For HRM to be strategically integrated in sustainability strategy of the business, the HR function is integrated in formulation and in the implementation process as well (Wright et al., 2005; Chanda & Shen, 2009). Strategy formulation and implementation can be separated but are integral to the success of the strategic formula. Therefore, HRM strategic integration should be measured in both formulation and in implementation. This framework is shown in the operational model. The HRM business strategy formulation relies on development of HR strategy and HR involvement. The greater the extent to which HR influences the strategic decision, it becomes effective, internally consistent, and strategically focused.

The implementation of strategies is action-oriented and involves all HRM

functions, including recruitment and selection, training and development, performance management, compensation and rewards, employee involvement and safety and well-being.

Figure 3.1 depicts an operational model linking the HRM strategic integration in business sustainability strategy and the organizational performance. The basic structure of the model is in line with the model used by Chanda and Shen (2009).

Moreover, based on the objectives, the research questions and, subsequently, hypotheses were framed. Research design adopts the quantitative research method for this study. This includes design of sampling frame, variables and measures, questionnaire design, and the reliability testing of the research instrument the designed questionnaire. The following tables provide details of all these.

Table 3.1. Objectives of the study and the related research question and hypotheses for business sustainability role for HRM

Objectives for the Study	Research Questions	Hypotheses
To find HRM strategic integration in business sustainability strategy	How would one know the HRM in the organization has strategic integration in business sustainability strategy?	H1: There is a significant relationship between the HRM strategic integration FORMULATION and IMPLEMENTATION of the sustainability strategy.
To find the relationship of HRM strategic integration in business sustainability strategy and the organizational performance.	How would one know that this integration has impact on organizational performance?	H2a: HRM strategic integration is related to the PEOPLE factor of the organizational performance. H2b: HRM strategic integration is related to the PLANET factor of the organizational performance. H2c: HRM strategic integration is related to the PROFIT factor of the organizational performance.
To find the effect of the organizational characteristics on this causal relationship between The HRM strategic integration and the organizational performance.	Does the organizational characteristics like age of the business, size of the business influence this causal relationship?	H3a: The organizational characteristics, age of the company influences the relationship between the strategic integration and the organizational performance. H3b: The organizational characteristics, employees' strength of the company influence the relationship between the strategic integration and the organizational performance.

Table 4.1. Research method

SAMPLING & SAMPLE SIZE	SAMPLES	RESEARCH METHOD	DATA ANALYSIS
KARNATAKA REGION INDIAN MANUFACTURING SECTOR SAMPLE SIZE: N = 233	LARGE MANUFACTURING COMPANIES LISTED IN FKCCI DIRECTORY Samples representation from – Companies from those sectors contributed to 80% of state GDP classified under the Karnataka Industrial Census bureau. Companies benchmarked either with ISO 9000, ISO 14000, OSHA or any equivalent standards. Companies representation from all parts of Karnataka Age of the company ranges from min 5years to maximum 126 years. Employees’ strength ranges from minimum of 50 to maximum of 36000. Respondents from senior executives of HR and NON HR divisions.	Quantitative Research Method SEM is used to analyze the data to validate the hypotheses. Data Collection: Questionnaire with a measure of 5-point Likert interval scale. (Reliability of the questionnaire tested with CFA & Cronbach’s Alpha test & has a significance alpha value >8.0 for all the factors). Secondary data through the Official Websites of the Companies. Response rate: 40%	Demographic Analysis – % of total size of the sample Vs. Product Sector, Age and Employees’ strength is shown in the form of a Stacked Bar chart. Normality Test – Skewness & Kurtosis values show the significance value. Normality test conducted using XLSTAT shows a significant result by accepting the H0 stating the data set falls under normal distribution. Structural equation modelling through Amos 20.0 software is used to validate the hypotheses.

STACKED BARCHART SHOWING THE DEMOGRAPHY OF THE RESPONDENTS IN % OF REPRESENTATION (N=233)

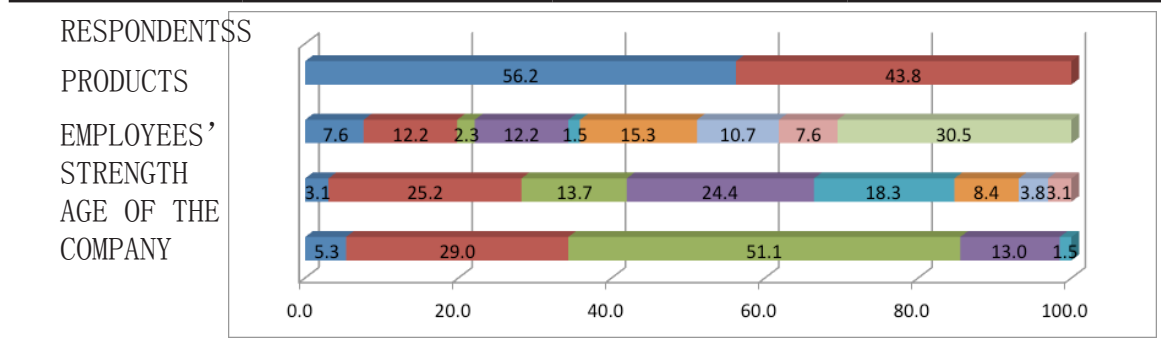

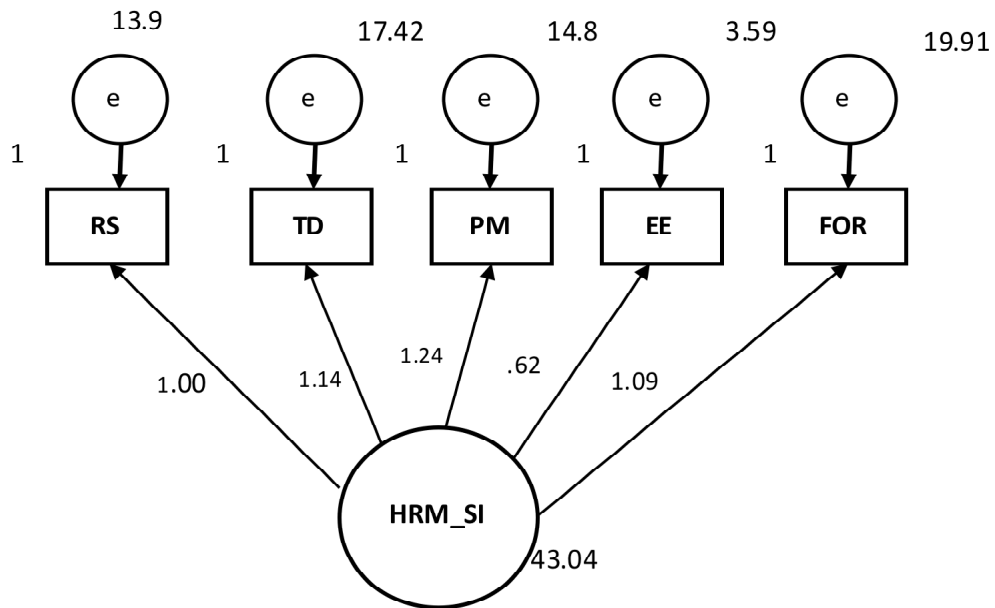

Model fit data obtained:

Cmin/DF: 1.846; GFI 0.988; AGFI: 0.954; CFI: 0.997; RMR: 0.46; RMSE: 0.060
 Standard Criteria for model fit statistics (Wu, 2005; Hair et al., 2006; Lee et al., 2012)
 Cmin/DF <= 3; GFI; AGFI; CFI>0.9; RMR<0.05; RMSE<0.08

Figure 5.1. SEM model showing the association of HRM strategic integration in formulation and implementation of sustainability strategy in business

TESTING OF HYPOTHESES

The standardized regression estimate allowed us to examine the direct association between the constructs. We note that the level of significance is based on the critical ratio (CR) of the regression estimate (Byrne, 2001). Thus, CR values greater than or equal to 2.58 indicate a 99% level of significance. Accordingly, we report that HRM strategic integration in sustainability strategy (HRM_SI) has a positive significance on constructs SI_FOR, RS_SI_IMPL, TD_SI_IMPL, PM_SI_IMPL, and EE_SI_IMPL.

Consequently, we accept *Hypothesis 1: There is a significant relation between the HRM strategic integration*

in formulation and implementation of sustainability strategy in business.

A mediator is instrumental in accounting for the influence of the independent variables on the dependent variables (Cohen & Aiken 2003). To test the mediation of the strategic integration of HRM (role for HRM), we followed the suggestions (Wood et al., 2008) and applied SEM procedures using a maximum-likelihood estimation (MLE) algorithm. It has been previously discussed in different papers (Elhuni & Ahmad 2014; Lee, 2012; Katou & Budhwar, 2009) that, in the mediation analysis when variables with multiple indicators are taken into account or conditions of confirmatory analysis are met or models incorporate

Table 5.2. Standardized regression weights with CR & P level

	PATH		Estimate	CR	P
RS	<---	HRM_SI	.869		
TD	<---	HRM_SI	.912	19.985	0.001
PM	<---	HRM_SI	.904	19.631	0.001
EE	<---	HRM_SI	.907	19.793	0.001
FOR	<---	HRM_SI	.848	21.452	0.001

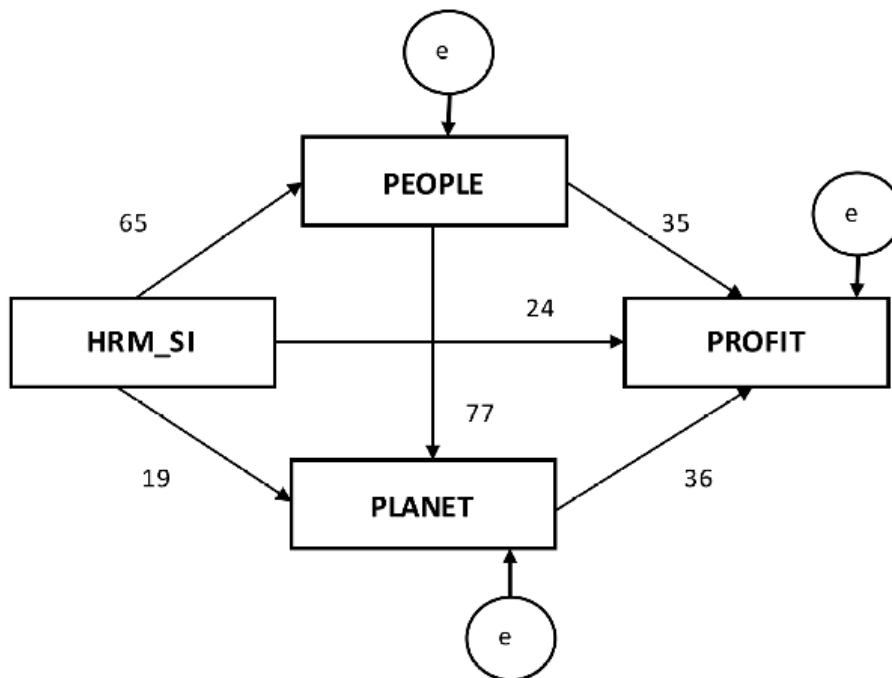

Model fit data obtained:

GFI: 1.000; AGFI: 1.000; RMR: 0.00; RMSE: 0.000

Standard Criteria for model fit statistics (Wu, 2005; Hair et al., 2006; Lee et al., 2012)

Cmin/DF ≤ 3; GFI; AGFI; CFI > 0.9; RMR < 0.05; RMSE < 0.08

Figure 5.2. SEM model showing the impact of HRM strategic integration in sustainability strategy and the people, planet, and profit factors of the organizational performance in business

latent variables, SEM offers a better alternative to traditional multiple regression tests of mediation.

The standardized regression estimate presented in the Table 5.2 allowed us to examine the direct association between the constructs. We note that the level of significance is based on the critical

ratio (CR) of the regression estimate (Byrne, 2001). Thus, CR values greater than or equal to 2.58 indicate a 99% level of significance. Accordingly, we report that HRM strategic integration in sustainability strategy (HRM_SI) has positive significance on the organizational performance constructs: people, planet, and profit.

Table 5.2. Standardized regression weights with CR & *p* level

	PATH		Estimate	CR	<i>P</i>
PEOPLE	<---	HRM_SI	.652	13.11	0.001
PLANET	<---	HRM_SI	.189	5.08	0.001
PLANET	<---	PEOPLE	.768	20.59	0.001
PROFIT	<---	HRM_SI	.240	05.48	0.001
PROFIT	<---	PLANET	.363	4.95	0.001
PROFIT	<---	PEOPLE	.351	5.02	0.001

Consequently, we accept Hypotheses 2a, 2b, and 2c. There is a significant positive relation between the HRM strategic integration in sustainability strategy and people, planet, and profit factors of the organizational performance in business.

The influence of organizational characteristics shows insignificance; hence, Hypotheses H3a and H3b are rejected.

The results of the present study provide ample support for the proposed theoretical model given in the research framework.

DISCUSSIONS

Any typical manufacturing business starts with the conceptual stage by combining science, technology, and social needs to create an innovation or invention in the form of product(s). The next stage is the compliance stage where the product is tested for feasibility and viability. Once this testing has proven that the product is viable, the commercial stage with inputs, processing, output, and residue in line produces the product. This product will enter the business environment and faces the market competition in the competition stage. The success or failure of this business depends on how well the product responds to the dynamic VUCA business environment

and beats the market competition. It is well known that there is a finite set of financial and nonfinancial factors in which to consider a firm's failure. Despite those factors, business/firms are able to operate in this dynamic business environment due to the different combinations of strategies the firm typically adopt to overcome the hurdles. An organization's success depends not only on the creative strategies the TMT utilizes but also the way the strategies are translated into policies, practices, process, and the actual implementation of these. Hence, the role for HRM in an organization is to manage those minds responsible for such creative strategies and also facilitation and the implementation of those strategies in collaboration with other functional areas, which leads the business toward sustainability.

In line with this explanation, this study is proposing the I4C model to represent the role for HRM in business sustainability.

In this study, the role for HRM is studied through the construct of HRM strategic integration of business sustainability strategy. The HRM strategic integration will be through the involvement of the HR in the strategy formulation and aligning the HRM strategies with the business strategies

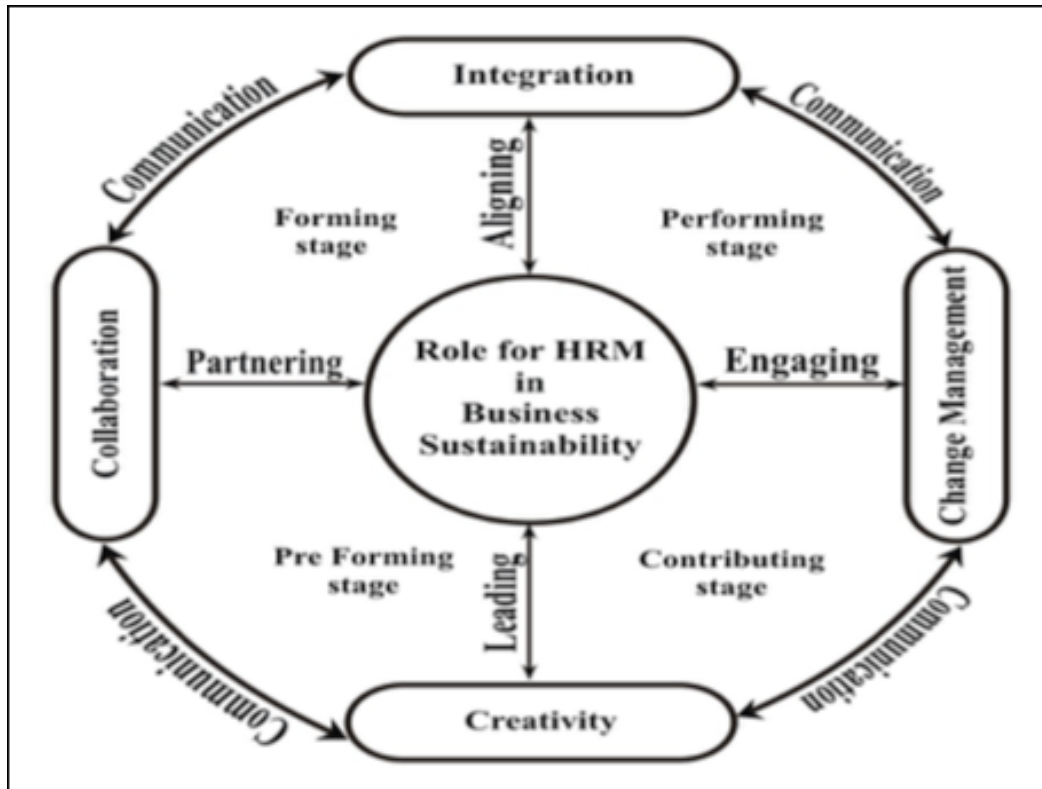

Figure 6.1. I4C model: business sustainability role for HRM

formulated. In this study considering sustainability as a business strategy, the HRM strategic integration is tested for its formulation and implementation levels through the functions of HRM. The statements “HR’s presence in the company’s board,” “HR in the C-suit,” and “HR reporting to the C-suit” confirm the involvement of the HR in the strategy formulation. The implementation level revealed through the following functions of HRM, recruitment and selection, training and development, performance management, compensation and reward, employee involvement and safety and welfare.

Based on the statistical analysis results, this study on Indian manufacturing companies reveals that HRM is more active in implementation compared with formulation of strategies. About

60% of the companies under study have agreed upon the HR’s role in the formulation of business strategy. The statistical significance tests revealed the positive significant association of the formulation and implementation of HRM strategic integration. Further, the ANOVA test and chi-square tests reveal the positive impact of the strategic integration on the performance of the organization in all the three factors of sustainability people, planet, and profit.

This affirms that HRM in an organization has potential to contribute important skills and to support the business to transform itself for greater sustainability. HRM takes a leading partnership role in developing and implementing sustainable business strategy through the skills in organizational process and change management.

The unique skills and knowledge of each and every employee are the sources of competitive advantage. This CA can be leveraged to create sustainability-linked targets for performance, compensation and rewards, training and development, and value-based recruitment using sustainability-based employer branding.

The tangible outcomes of strong sustainable HRM performance include support for the achievement of broad sustainability business objectives, measurable contributions to HRM performance, including lower rate of employee turnover, lower percentage of absenteeism, improved employee well-being, and an overall increase in motivation, employee involvement and productivity.

Other studies, too, have confirmed that, when the corporate sustainability leadership consider HRM as a critical contributor, HRM can redirect itself and the organization toward sustainability. HR managers' involvement through collaboration, consultation, and demand for HRM accountability incorporates sustainable HRM practices. At the same time, HR professionals must update their approach from transactional or transformational HRM to strategic and to sustainable HRM.

It is also evident that there is strong correlation between HRM strategy and sustainability. The HRM strategy is the ways and means of administering HR in a SMART tangible roadmap in its implementation through agreeable set targets. In retrospect, while integrating sustainability in the planning matrix, one reassures that HRM is deliverable in the short-, medium-, and long-term for present and future generations in an operational environment that is ever supportive and enriched (Wittenberg, 2012).

CONCLUSION

The human resource management function is crucial to achieve success in a sustainability-driven organization. Sustainability is all pervasive. Sustainability practices in each and every aspect of doing business have been embedded across organizations at all levels. It has become an ongoing change process. Because the prime focus and skills of human resource professionals include organizational process, change management, and culture stewardship, they should take a leading role in developing and implementing sustainability strategy, which in turn contributes to the organizational performance.

The results of this study reaffirm the HRM's role in business sustainability. HRM, through the strategic integration in the formulation and implementation the practices in processes, can bring in the culture of sustainability in the organization. HRM is not only serving as a tool to implement sustainability but also as an object of sustainability. Sustainability is considered not just as an end or means for any process, it is considered as a management and leadership philosophy that enables people to contribute success at their work by minimizing the negative impact of their work on the environmental and social factors and at the same time improving the financial factors in the organizations.

Academic and Managerial Implications

The present study makes both academic and practical contributions and suggests some applications for the research.

As to the managerial implications, the HRM strategic integration in the formulation and implementation level covers most of the practices used in the organizations, constituting an important evaluation instrument for managers to improve their employee's sustainability quotient at work. There is a consensus in the literature that HRM strategic integration has a positive impact on the organizational performance. The I4C model—the role for HRM in business sustainability—provides a better understanding of the interconnectedness of the various factors in bringing sustainability culture to an organization. This adds to the already published theoretical and empirical evidence of HRM policies and practices favorably affect organizational performance.

Limitations and Directions for Future Research

This research has limitations and consequently recommendations for future studies. Our study represents an attempt to build and test a conceptual framework of HRM strategic integration in business sustainability strategy and studies the impact of this

on the organizational performance. One of the study's limitations is that the present findings are indicative rather than conclusive. India has a vibrant multidimensional demography, and this study covered only the Karnataka region due to the practical difficulty in approaching companies in the other parts of India. The multisectors' representation of samples covers only the sectors that have contributed to 80% of the state GDP. The study was conducted on only large manufacturers registered with FKCCI.

It would be useful to further assess and generalize the HRM strategic integration with sector-specific and region-specific studies.

Another limitation is this study has considered only the most widely cited processes of HRM viz., R&S, T&D, PM, & EE. Studying from policy and practices level may provide more focused inferences.

Finally, the findings of this study were not intended to be conclusive or limiting but offer a useful starting point for further theoretical and empirical research on HRM and sustainability links.

References

- Asta, Savaneviciene and Zivile, Stankeviciute (2013), Sustainability as a concept for human resource management, *Economics and Management*, 18 (4) ISSN 2029-9338 (ONLINE)
- Bruntland, A (1987), *Our common Future*, WCED (World Commission on Environment and Development), Oxford Univ. Press, Oxford.
- Byrne, B.M (2001), *Structural equation modeling with AMOS: basic concepts, application and programming*. Mahwah, NJ: Lawrence E Associates Publishers.
- Chanda, Ashok and Shen, Jie (2009), *HRM strategic integration and organizational performance*, Sage Publication.
- Colbert, B.A. and Kurucz, E.C. (2007), “Three conceptions of triple bottom line business sustainability and the role for HRM”, *Human Resource Planning*, Vol. 30 No. 1, 21-29.
- Jackson S E and Seo J (2010), the greening of strategic HRM scholarship. *Organizational Management Journal* 7, 278-290
- Jackson, S E & Schuler, R S (1995), Understanding human resource management in the context of organisations & their environments. *Annual Review of Psychology*, 46(1):237
- Katou, A A and Budhwar, P S (2009), Causal Relationship between HRM Policies and Organizational Performance Evidence from Greek Manufacturing sector, *European Management Journal*, doi: 10.1016/j.emj.2009.06.001
- Kiron, D., et al., (2012), Sustainability nears a tipping point. *MIT Sloan Management Review*, 53(2), 69–74.
- Paauwe, Jaap (2009), HRM and Performance: Achievements, Methodological issues and prospects, *Journal of Management Studies* 46(1) ISSN 0022-2380
- Parkes, Carole and Borland, Helen (2012), Strategic HRM: Transforming its responsibilities towards ecological sustainability - The greatest global challenge facing organisations, *Thunderbird International Business Review*, Vol 54, No.6, Nov/Dec 2012. DOI 10.1002/tie.21505
- Prahalad CK. (1983), Developing strategic capability: an agenda for top management. *Human Resource Management* 22(3): 237–254.
- Renwick, D., et al (2011), State of the art and future directions for green human resource management: Introduction to special issue, *German JI. of Research in Human Resource Management*, 25(2), 99-290.

Rishiksha, Krishna (2005), Linking Corporate strategy and HR strategy for HR professionals, In Padaki., et al., *Emerging Asia: An HR agenda*, New Delhi, Tata McGraw Hill, p 215-223

Report: Strandberg Consulting, (2009), *The Business Case for Sustainability*.

Report: SHRM (2010), *HR's role in Corporate social responsibility and Sustainability*.

Wirtenberg, J., et al., (2007), "HR's role in building a sustainable enterprise: insights from some of the world's best companies", *Human Resource Planning*, Vol. 30 No. 1, pp. 10-20.

Wood R E et al., (2008), Mediation testing in management Research: A review and proposals. *Organizational Research Methods*, 11(2), 270-295.

World Wild Fund (2010), *Living Planet report*. Retrieved from http://wwf.panda.org/about_our_earth/all_publications/living_planet_report/